

# TA-170

## SPECIFICATIONS

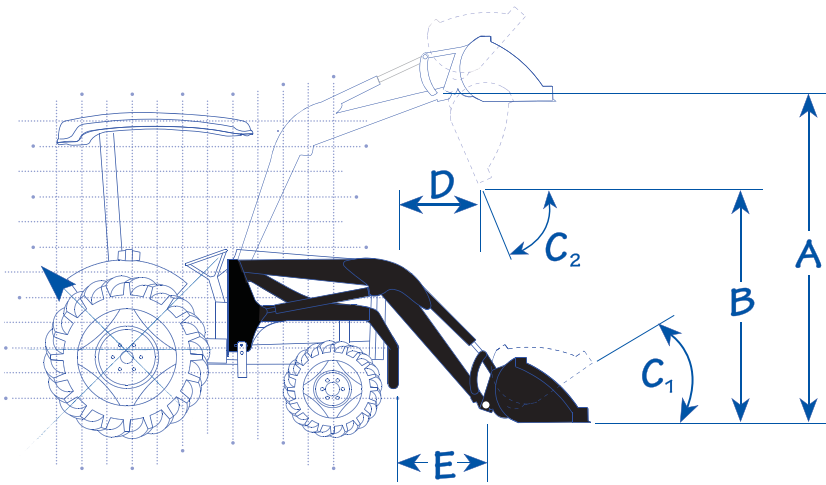

- A) Lift Height: **122" - 10'2"**
- B) Clearance: **98" - 8'2"**
- C) Bucket Roll Back Angle: **27°**  
Bucket Dump Angle: **51°**
- D) Reach at Max Height: **18"**
- E) Reach at Ground Level: **24"**

	1800 PSI	2200 PSI
Lift Capacity - AWC* (31.5" forward from pin)	1450	1770
Lift Capacity - Pivot Pin	1950	2380

\*AWC - Actual Working Capacity

## PACKAGE COMPONENTS

- Hydraulic Power-Mount™
- Quick-Attach System
- Hose Kit
- Standard Bracket Set
- One Lever Joystick with Valve and Manifold Kit

- Bucket Gauge Rod
- 2" Lift & Bucket Cylinders
- 60" Tapered Bucket
- 66"-72" Tapered Bucket (opt)
- 60"-66" Skid Steer Bucket and Adapter (opt)

## LOADER SPECIFIC UPGRADES & ATTACHMENTS

### Loader Upgrades

- Hydra-Snap™
- Hydraulic Valve Block
- Comfort Ride
- Power Beyond

- 3-Prong Bale Spear
- 60" Bucket Teeth
- 60" Dozer Blade
- 72" Snow Scraper
- 72" V-Plow
- Forklift with 42" Teeth
- Brush Crusher™
- Brush Crusher™ Finishing Teeth



## WESTENDORF MANUFACTURING CO. INC.

P.O. BOX 29 • ONAWA, IA 51040 • PH: (712)423-2762 • FAX:(712)423-1460  
Email: sales@westendorfmfg.com Website: www.loaders.com