

## BASIC LANDSCRAPER™ MAIN SHELL REPLACEMENT PARTS

REF #	PART #	DESCRIPTION	QTY
1	LS-201AS	MAIN SHELL - 8 FT.	1
	LS-101AS	MAIN SHELL - 10 FT.	1
	LS-1AS	MAIN SHELL - 12 FT.	1
2	LS-45AS	TONGUE	1
3	LS-212	WELD ON BLADE - 8 FT.	1
	LS-112	WELD ON BLADE - 10 FT.	1
	LS-12	WELD ON BLADE - 12 FT.	1

REF #	PART #	DESCRIPTION	QTY
4	OH-19	HOSE HOLDER	3
5	HTN0616	3/8" LOCK NUT	3
6	HHS1210048	3/4" X 3" BOLT	8
7	LWM12	3/4" LOCK WASHER	8
8	HFN1210	3/4" NUT	8

*NOTE: Some small parts and hardware are included in the bolt bag.*

WESTENDORFMFG PWB119190

WESTENDORF MFG CO., INC. • PH: (712) 423-2762 • FAX: (712) 423-1460 • sales@westendorfmfg.com • www.loaders.com

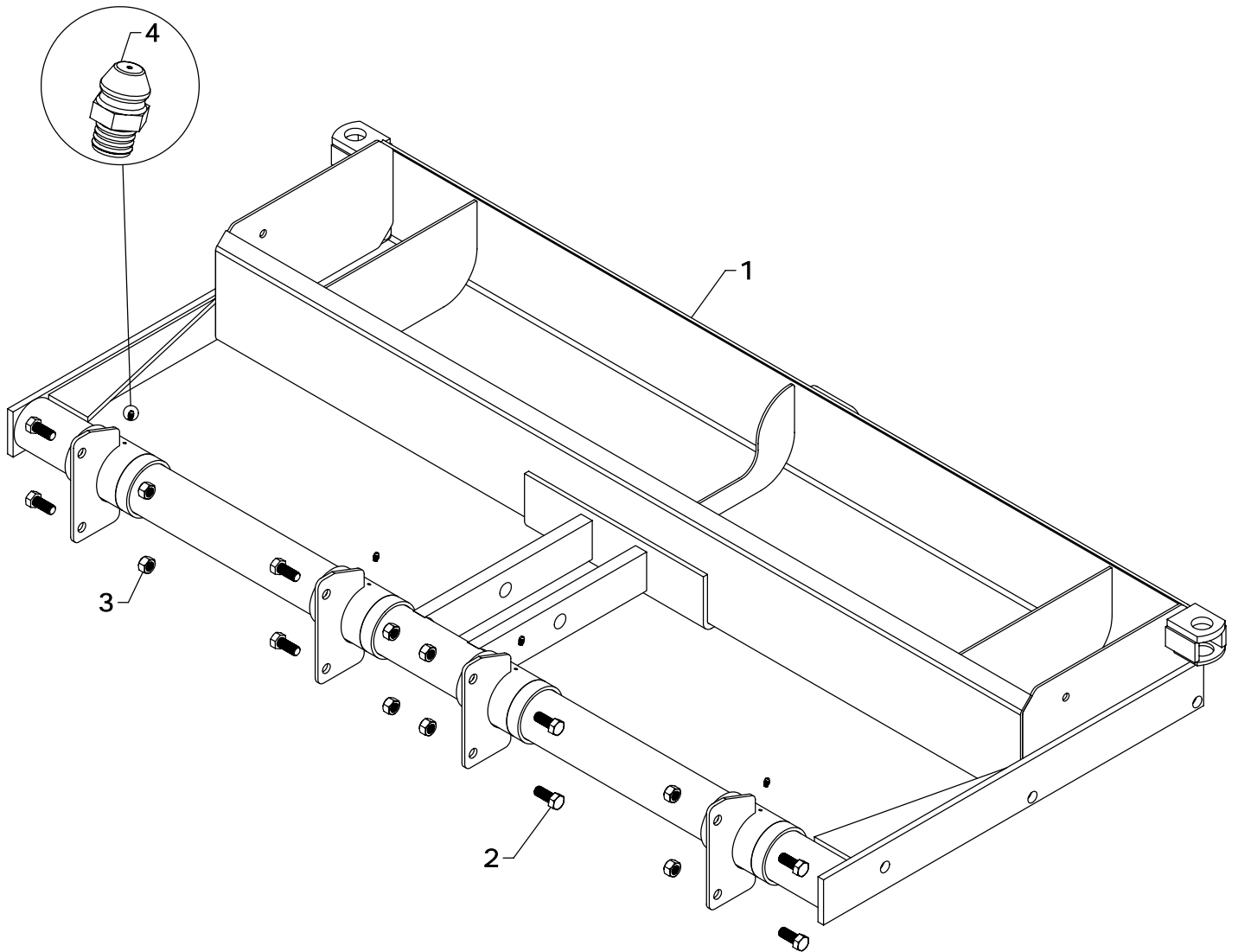

## BASIC LANDSCRAPER™ WEIGHT BOX REPLACEMENT PARTS

REF #	PART #	DESCRIPTION	QTY
1	LS-202AS	WEIGHT BOX - 8 FT.	1
	LS-2AS	WEIGHT BOX - 10 FT. & 12 FT.	1
2	HHS1011024	5/8" X 1 1/2" BOLT	8

REF #	PART #	DESCRIPTION	QTY
3	HTN1011	5/8" LOCK NUT	8
4	ZER1805	GREASE FITTING	4

*NOTE: Some small parts and hardware are included in the bolt bag.*

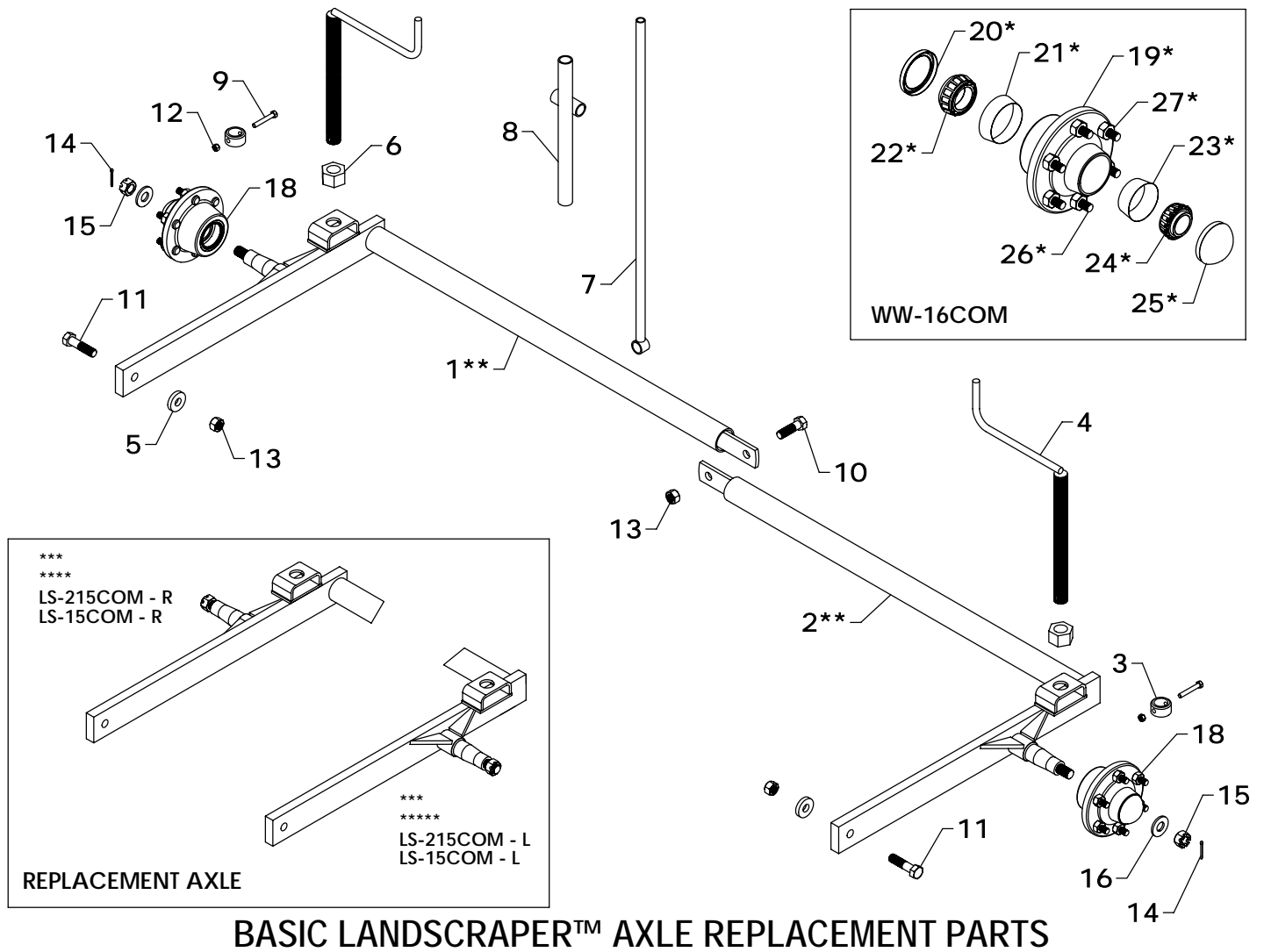

## BASIC LANDSCRAPER™ AXLE REPLACEMENT PARTS

REF #	PART #	DESCRIPTION	QTY
1**	LS-215AS-R	AXLE RIGHT - 8 FT.	1
	LS-15AS-R	AXLE RIGHT - 10 FT. & 12 FT.	1
2**	LS-215AS-L	AXLE LEFT - 8FT.	1
	LS-15AS-L	AXLE LEFT - 10 FT. & 12 FT.	1
3	QC-102	BUSHING WITH HOLE	2
4	LS-38AS	CRANK	2
5	LS-46	SPACER	2
6	LS-60	ADJUSTMENT NUT	2
7	LS-50AS	GAUGE ROD	1
8	LS-52AS	GAUGE ROD HOLDER	1
9	HHS0616040	3/8" X 2 1/2" BOLT	2
10	HHS1210040	3/4" X 2 1/2" BOLT	1
11	HHS1210048	3/4" X 3" BOLT	2
12	HTN0616	3/8" LOCK NUT	2
13	HTN1210	3/4" LOCK NUT	3
14	CTK0250024	5/32" X 1 1/2" COTTER PIN	2

REF #	PART #	DESCRIPTION	QTY
15	HSN1414	7/8" SLOTTED NUT	2
16	HW-26	SPINDLE WASHER	2
17	1566	15" X 6" - 6 BOLT RIM (NOT SHOWN)	2
18	WW-16COM	HUB COMPLETE	2

WW-16COM			
REF #	PART #	DESCRIPTION	QTY
19*	WW-16	HUB	1
20*	HD-35	GREASE SEAL	1
21*	HD-32	INSIDE RACE	1
22*	HD-42	INSIDE BEARING	1
23*	HD-276	OUTSIDE RACE	1
24*	HD-136	OUTSIDE BEARING	1
25*	8034	HUBCAP	1
26*	916WB	WHEEL BOLT	6
27*	916WN	WHEEL NUT	6

**NOTE:** WW-16COM contains 19 (1), 20 (1), 21 (1), 22 (1), 23 (1), 24 (1), 25 (1), 26 (6), and 27 (6).

\*Check measurements and numbers for possible differences in your Landscaper™ and this years model.

\*\*This part is not for resale. Order the "COM" if replacement parts are needed.

\*\*\* Use this part number when ordering replacement parts. \*\*\*\* Contains 1 (1) and 15 (1). \*\*\*\*\* Contains 2 (1) and 15 (1).

WESTENDORFMFG PWB119190

WESTENDORF MFG. CO., INC. • PH:(712) 423-2762 • FAX: (712) 423-1460 • sales@westendormfg.com • www.loaders.com

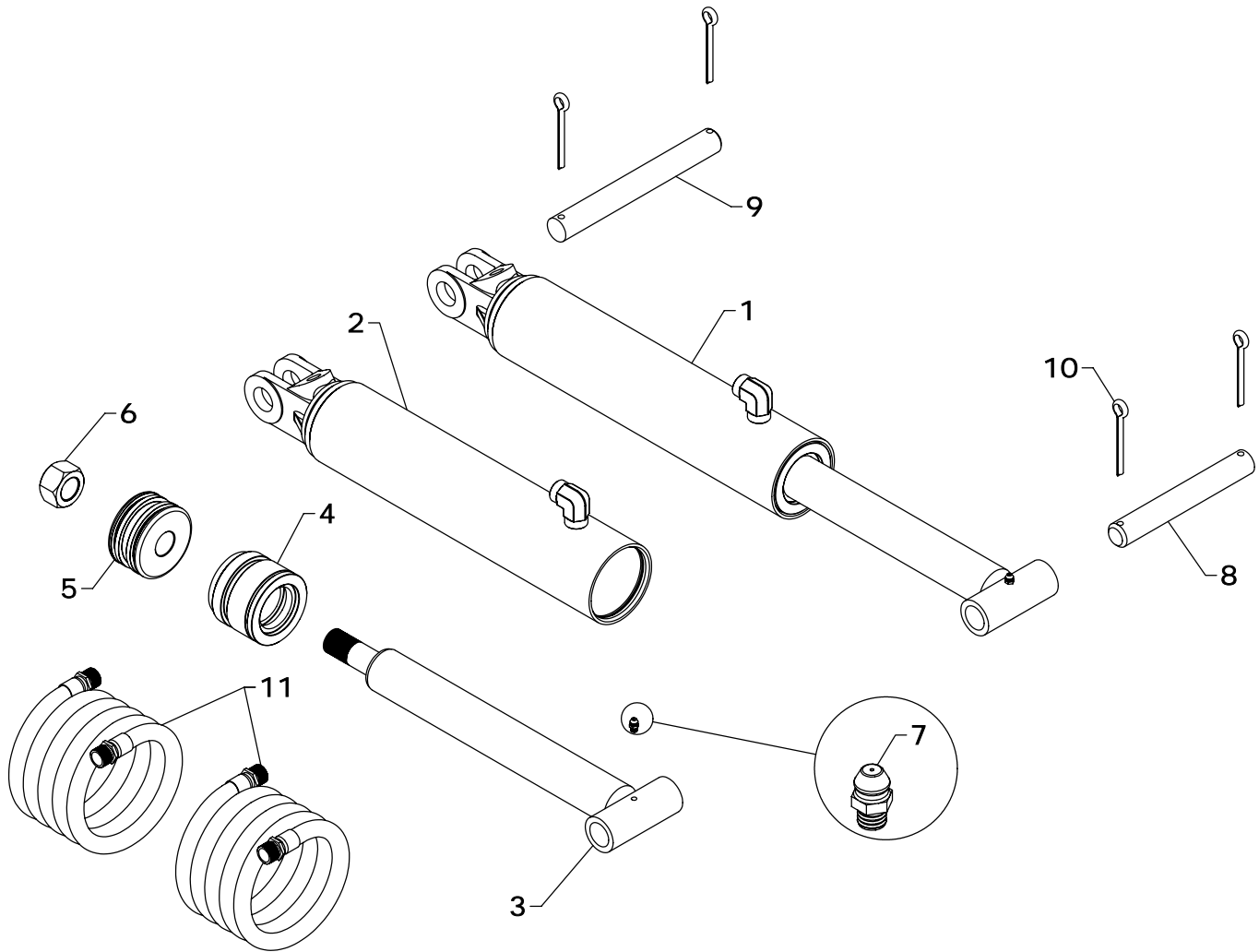

### STEPS TO REPAIR CYLINDER

- 1) Extend the ram out as far as possible.
- 2) At the ram end of the cylinder barrel you will find a snap ring located either on the face or inside the notch of the gland.
- 3) Locate the snap ring eyes (you may need to turn the gland inside the barrel to find the snap ring eyes). Compress the snap ring with snap ring pliers.
- 4) Remove the ram assembly (ram, gland, & piston) from barrel.
- 5) Notice the direction they're pointing so they can be properly re-assembled.
- 6) Remove the jam nut and/or hex nut from the end of the ram.
- 7) Remove the old seals and rings and replace them with the new seals and rings. (Seal kits are packaged for several different cylinders. You may have extra parts)
- 8) Clean cylinder with cleaner and a clean lint free cloth.
- 9) Lubricate the seals and rings to aid assembly.
- 10) Assemble the cylinder by reversing the order.

### CYLINDER REPAIR TIPS

- When disassembling cylinders, keep the parts in correct orientation. Remove parts in sequence.
- Note the direction of the piston and gland. Lay out old seals and parts as they are removed.
- Assemble cylinder in proper order; lubricate to aid assembly.

## LIFT CYLINDER REPLACEMENT PARTS

REF #	PART #	DESCRIPTION	QTY.
1	L-2	LIFT CYLINDER	1
2	L-201	BARREL	1
3	L-210	RAM	1
4	G-B	GLAND	1
5	P-B	PISTON	1
6	HFN1614	1" NUT	1
7	ZER1805	GREASE FITTING	1
8	BF-59	PIN	1
9	LS-53	GAUGE ROD PIN	1
10	CTK0400032	1/4" X 2" COTTER KEY	4
11	HK-37	2 - 3/8" X 192" HOSE	1
12	#4CK	SEAL KIT	*

**NOTE:** \* Seal kit contains parts to repair one cylinder

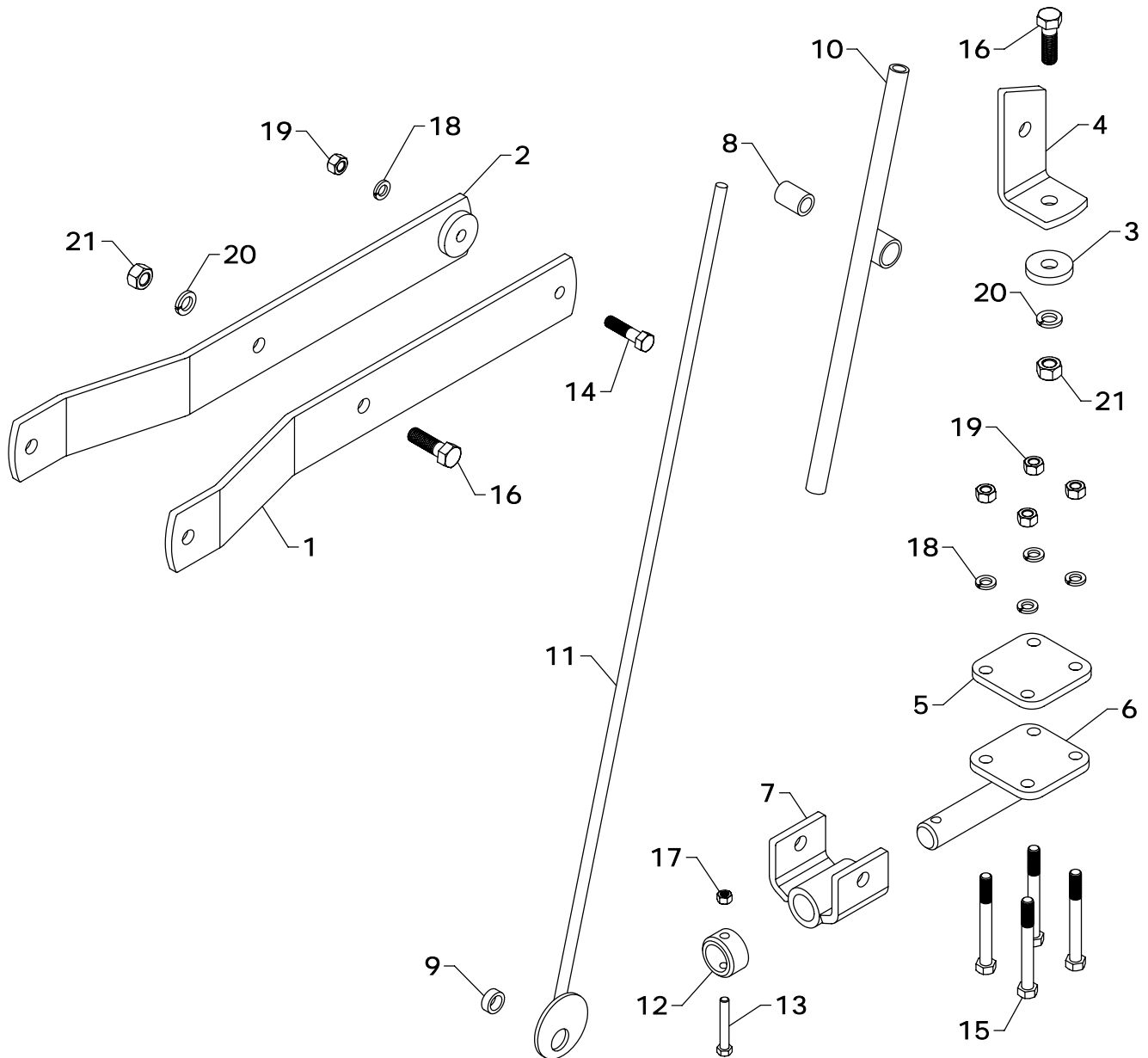

## OPTIONAL HYDRAULIC LEVELING

REF #	PART #	DESCRIPTION	QTY
1	LS-70	LINK ARM	1
2	LS-70AS	LINK ARM	1
3	LS-73	BOLT MOUNT	1
4	LS-74	LINK SUPPORT	1
5	LS-75	PIVOT CLAMP	1
6	LS-75AS	LOWER PIVOT	1
7	LS-77AS	CYLINDER MOUNT	1
8	LS-82	BUSHING (1 3/8" LONG)	1
9	LS-83	BUSHING (3/8" LONG)	1
10	JF-56AS	OUTER GAUGE ROD	1
11	JF-57AS	GAUGE ROD	1

REF #	PART #	DESCRIPTION	QTY
12	QC-102	BUSHING WITH HOLE	1
13	HHS0616040	3/8" X 2 1/2" BOLT	1
14	HHS0813032	1/2" X 2" BOLT	1
15	HHS0813072	1/2" X 4 1/2" BOLT	4
16	HHS1011032	5/8" X 2" BOLT	2
17	HTN0616	3/8" LOCK NUT	1
18	LWM08	1/2" LOCKWASHER	5
19	HFN0813	1/2" NUT	5
20	LWM10	5/8" LOCK WASHER	2
21	HFN1011	5/8" NUT	2

*NOTE: Some small parts and hardware are included in the bolt bag.*

WESTENDORFMFG PWB119190

WESTENDORF MFG. CO., INC. • PH:(712) 423-2762 • FAX: (712) 423-1460 • sales@westendormfg.com • www.loaders.com

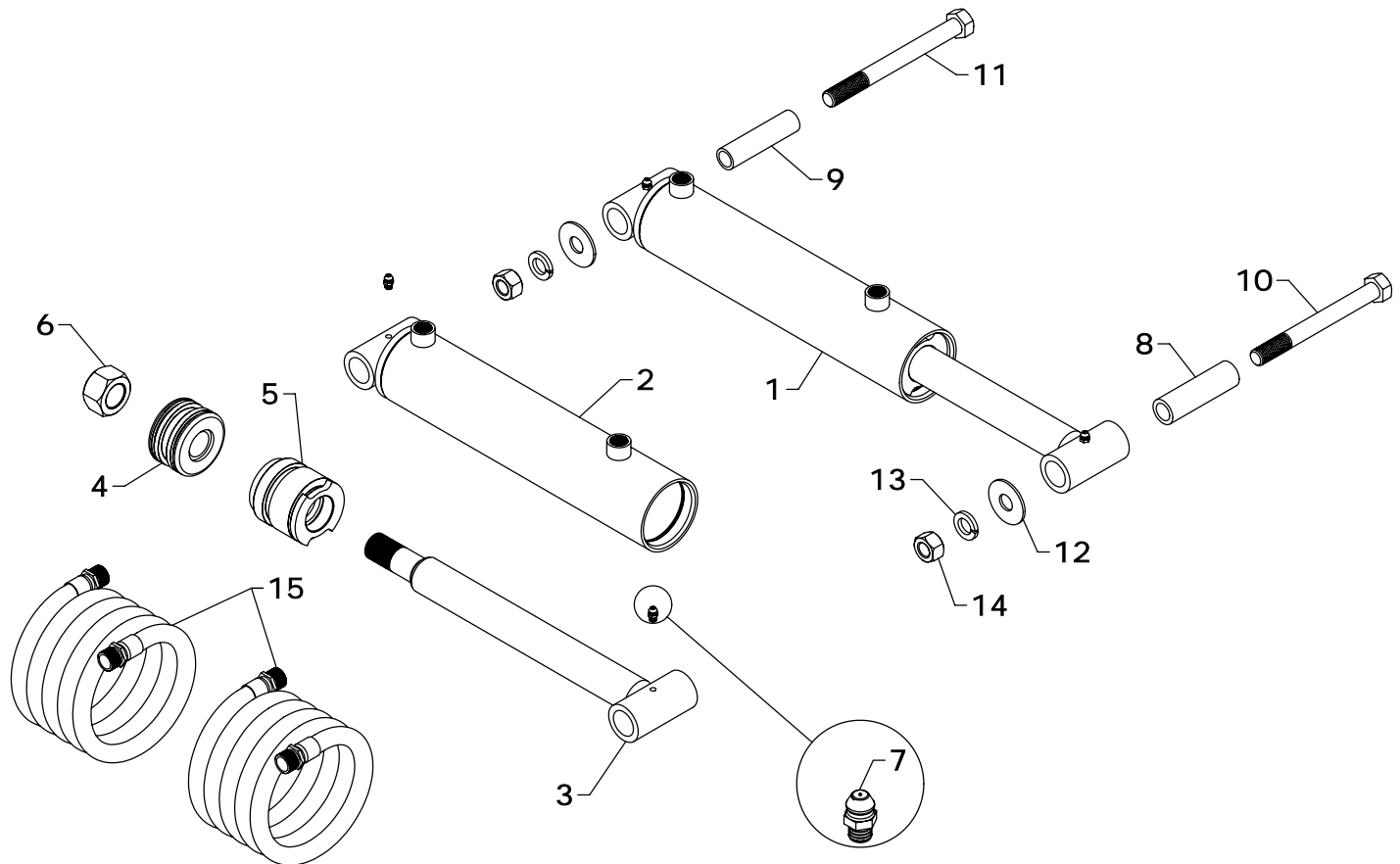

## OPTIONAL HYDRAULIC LEVELING CYLINDER

### STEPS TO REPAIR CYLINDER

- 1) Extend the ram out as far as possible.
- 2) At the ram end of the cylinder barrel you will find a snap ring located either on the face or inside the notch of the gland.
- 3) Locate the snap ring eyes (you may need to turn the gland inside the barrel to find the snap ring eyes). Compress the snap ring with snap ring pliers.
- 4) Remove the ram assembly (ram, gland, & piston) from barrel.
- 5) Notice the direction they're pointing so they can be properly re-assembled.
- 6) Remove the jam nut and/or hex nut from the end of the ram.
- 7) Remove the old seals and rings and replace them with the new seals and rings. (Seal kits are packaged for several different cylinders. You may have extra parts)
- 8) Clean cylinder with cleaner and a clean lint free cloth.
- 9) Lubricate the seals and rings to aid assembly.
- 10) Assemble the cylinder by reversing the order.

### CYLINDER REPAIR TIPS

- When disassembling cylinders, keep the parts in correct orientation. Remove parts in sequence.
- Note the direction of the piston and gland. Lay out old seals and parts as they are removed.
- Assemble cylinder in proper order; lubricate to aid assembly.

REF #	PART #	DESCRIPTION	QTY.
1	M-3	LEVELING CYLINDER	1
2	M-301	BARREL	1
3	M-310	RAM	1
4	P-A	PISTON	1
5	G-A	GLAND	1
6	HFN1614	1" NUT	1
7	ZER1805	GREASE FITTING	2
8	LS-80	1" O.D. RAM INSERT BUSHING	1
9	LS-81	.84" O.D. BARREL INSERT BUSHING	1
10	HHS1011096	5/8" X 6" BOLT	1
11	HHS1011104	5/8" X 6 1/2" BOLT	1
12	FWW10	5/8" FLAT WASHER	2
13	LWM10	5/8" LOCK WASHER	2
14	HFN1011	5/8" NUT	2
15	HK-38	2 - 3/8" X 216" HOSE	1
16	#1CK	SEAL KIT	*

**NOTE:** \* Seal kit contains parts to repair one cylinder

**NOTE:** Some small parts and hardware are included in the bolt bag.

WESTENDORFMFG PWB119190

WESTENDORF MFG. CO., INC. • PH: (712) 423-2762 • FAX: (712) 423-1460 • sales@westendorfmfg.com • www.loaders.com

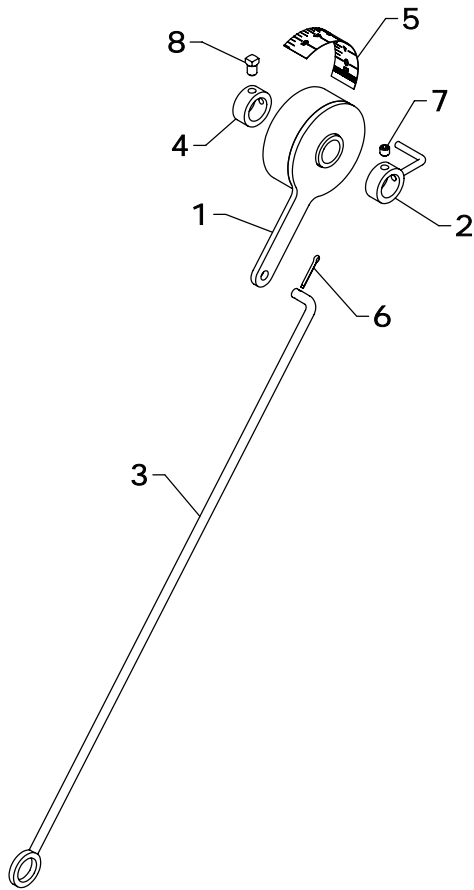

## OPTIONAL ROTATIONAL HEIGHT INDICATOR

LAC-25-17			
REF #	PART #	DESCRIPTION	QTY
1	GRD-41AS	LEVEL INDICATOR	1
2	GRD-2AS	POINTER	1
3	GRD-160AS	GAUGE ROD	1
4	BUS-105	BUSHING	1
5	DE-GRD	DECAL	1
6	CTK0200016	1/8" X 1" COTTER KEY	1
7	AHS0616006	3/8" X 3/8" ALLEN HEAD SET SCREW	1
8	SHS0616008	3/8" X 1/2" SQUARE HEAD SET SCREW	1

*NOTE: \*Order LAC-25-17 when ordering a complete Rotational Height Indicator Kit.*

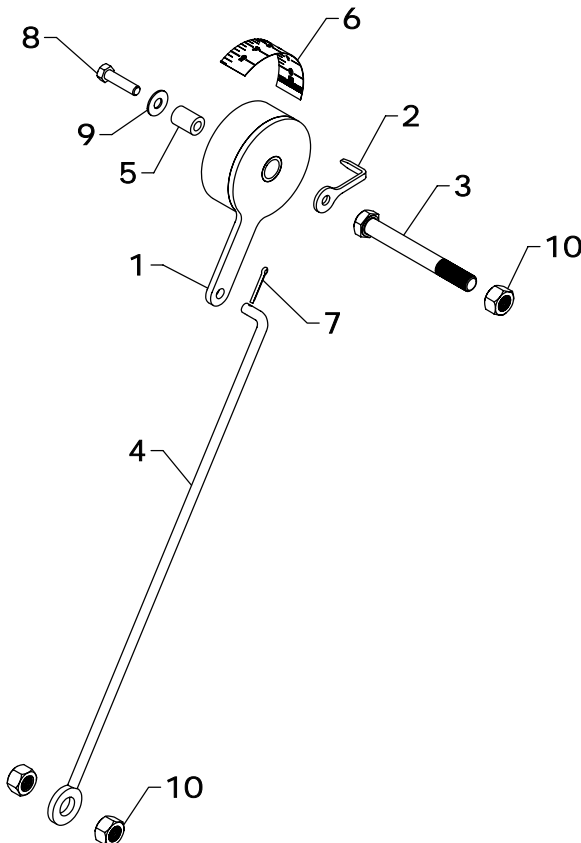

## OPTIONAL ROTATIONAL LEVEL INDICATOR

REF #	PART #	DESCRIPTION	QTY.
1	GRD-141AS	LEVEL INDICATOR	1
2	GRD-123	POINTER	1
3	GRD-108	THREADED END BOLT	1
4	GRD-165AS	GAUGE ROD	1
5	LM-4	NYLON BUSHING	1
6	DE-GRD	DECAL	1
7	CTK0200016	1/8" X 1" COTTER KEY	1
8	HHS0616024	3/8" X 1 1/2" BOLT	1
9	FWW06	3/8" FLAT WASHER	1
10	HTN1011	5/8" LOCK NUT	3

*NOTE: \*Order LAC-15-25 when ordering a complete Rotational Level Indicator Kit.*

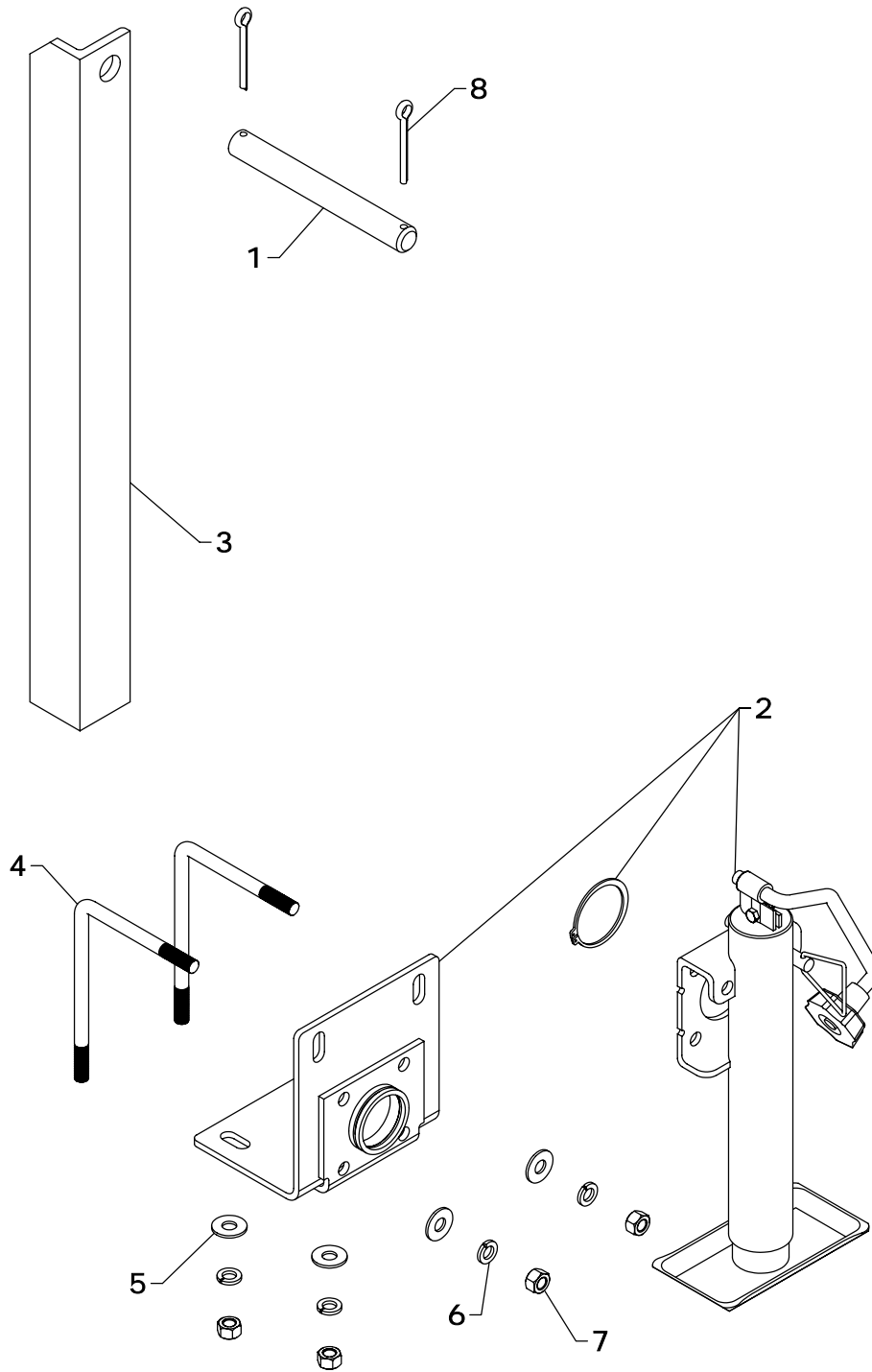

## OPTIONAL TRANSPORT LOCK AND JACK STAND

REF #	PART #	DESCRIPTION	QTY
1	LS-53	GAUGE ROD PIN	1
2	LS-64 KIT	JACK STAND KIT	1
3	LS-65	TRANSPORT LOCK	1
4	LS-67	JACK STAND BOLT	2

REF #	PART #	DESCRIPTION	QTY
5	FWW08	1/2" FLAT WASHER	4
6	LWM08	1/2" LOCKWASHER	4
7	HFN0813	1/2" NUT	4
8	CTK0400032	1/4" X 2" COTTER KEY	2

*NOTE: Some small parts and hardware are included in the bolt bag.*