

TA-76 / TA-77 LOADER TOWER REPLACEMENT PARTS

REF #	PART #	DESCRIPTION	QTY.
1	NBT-12AS - L	TOWER (LEFT)	1
2	NBT-12AS - R	TOWER (RIGHT)	1
--	NAT-120COM - R	SLIDE LOCK COMPLETE (RIGHT)	*
--	NAT-120COM - L	SLIDE LOCK COMPLETE (LEFT)	*
3	NAT-120AS - R	SLIDE LOCK (RIGHT)	1
4	NAT-120AS - L	SLIDE LOCK (LEFT)	1
5	NAT-106 - L	DROP LOCK (LEFT)	1
6	NAT-106 - R	DROP LOCK (RIGHT)	1
7	NAT-126	RIVET	2

REF #	PART #	DESCRIPTION	QTY.
8	RLG-51	SPRING	2
9	NAT-140	BAR CLAMP BOLT	4
10	CBF1011056	5/8" X 3 1/2" CARRIAGE BOLT	4
11	HTN1011	5/8" LOCK NUT	8
12	HHS1011028	5/8" X 1 3/4" BOLT	4
13	LWM10	5/8" LOCK WASHER	4
14	NAF-51	PIN	4
15	DRP0600032	DOUBLE ROLL PIN	4
16	0H013	FRONT WRAP	**

NOTE: * NAT-120COM - R contains 3(1), 6(1), 7(1), 8(1), 9(2), 10(2), 11(4). NAT-120COM - L contains 4(1), 5(1), 7(1), 8(1), 9(2), 10(2), 11(4).
 ** Varies by tractor (Standard Front Wrap is 0H013).

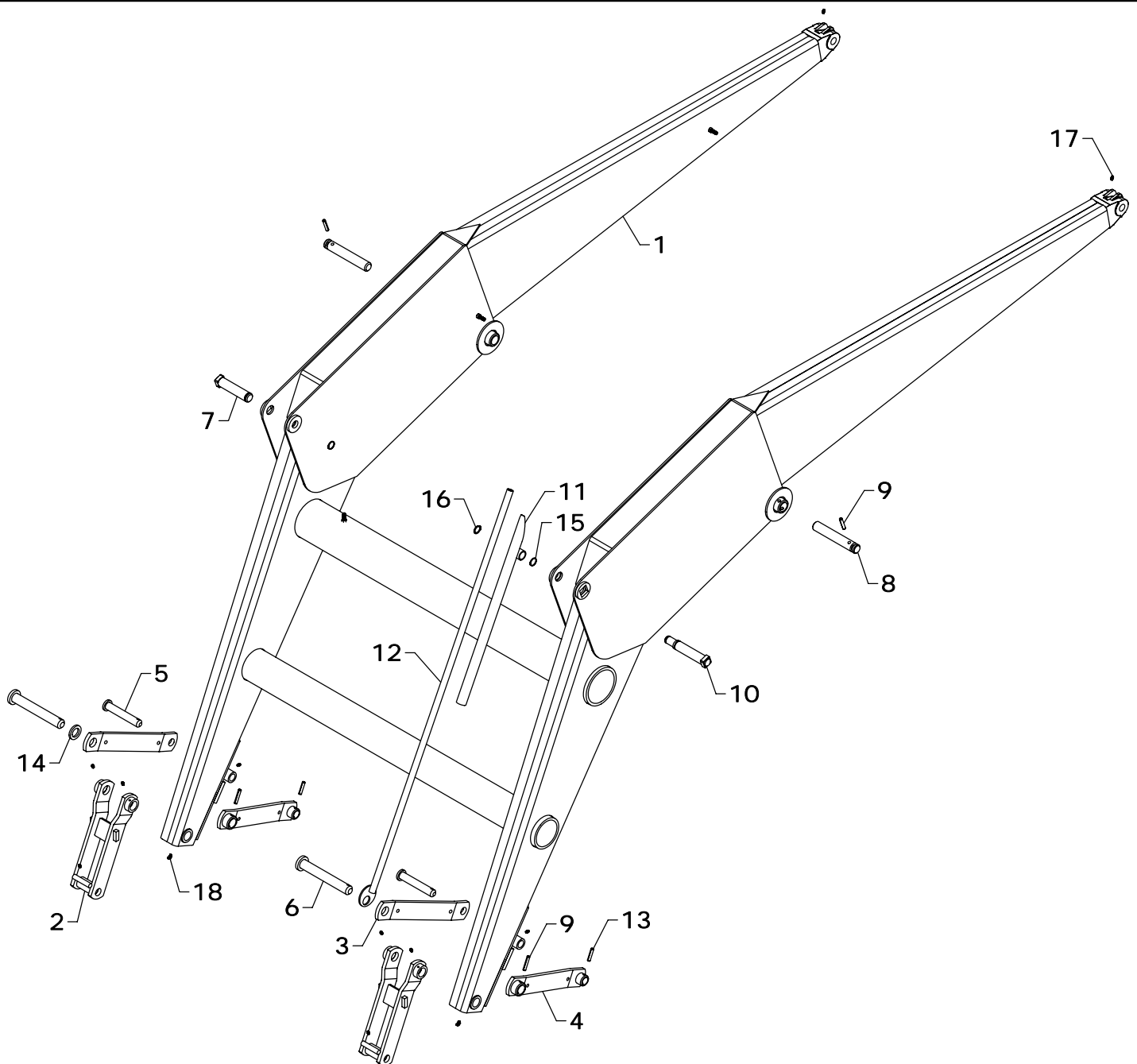

TA-77 LOADER FRAME REPLACEMENT PARTS

REF #	PART #	DESCRIPTION	QTY.
1	NBF-104AS	FRAME	1
2	NAF-15AS	LINKAGE CONNECTOR	2
3	NAF-10	BUCKET PIVOT	2
4	NAF-10AS	BUCKET PIVOT	2
5	LMF-28AS	PIVOT PIN	2
6	LMF-125AS	ROUND HEAD PIN	2
7	NAF-52AS	BUCKET CYLINDER PIN	1
8	LF-83	LIFT PIN	2
9	DRP0600032	DOUBLE ROLL PIN	4

REF #	PART #	DESCRIPTION	QTY.
10	NAF-53AS	GAUGE ROD HOLDER PIN	1
11	LMF-31AS	GAUGE ROD HOLDER	1
12	LMF-47AS	GAUGE ROD	1
13	DRP0600028	DOUBLE ROLL PIN	2
14	NAF-117	PIN HEAD	1
15	SR-C10	SNAP RING	2
16	SR-C08	SNAP RING	1
17	ZER1805	GREASE FITTING	10
18	ZER523	90° GREASE FITTING	2

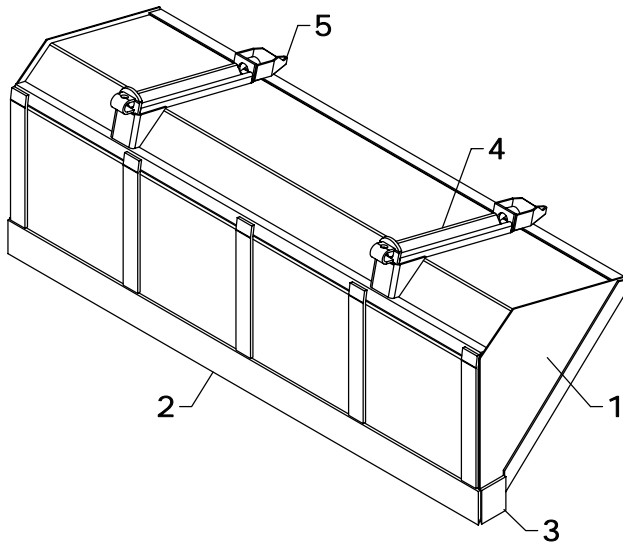

TA-76 / TA-77 BUCKET

REF #	PART #	DESCRIPTION	QTY.
1	96Q729	96" BUCKET	1
	108Q733	108" BUCKET	1
2	CB-14	96" BLADE	1
	UB-414	108" BLADE	1
3	SB-15	BLADE	2
4	QC-13AS	WELD ON ADAPTER	2
5	JB-22	GUIDE (OPTIONAL)	2

NOTE: *Check width of the bucket and use the part number that matches. If your size is not shown, contact Westendorf Mfg. Co.

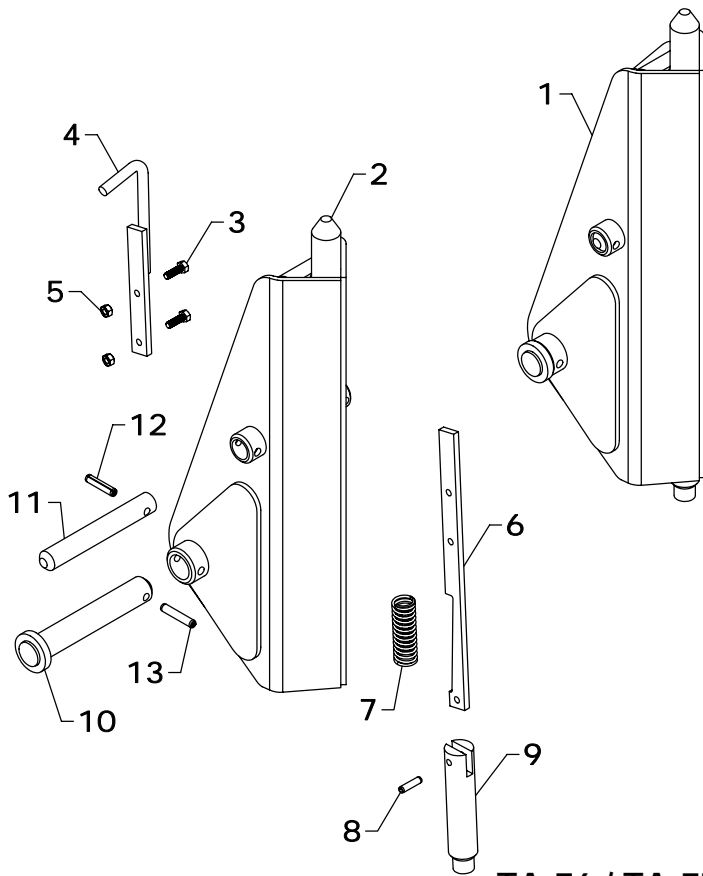

TA-76 / TA-77 SNAP-ATTACH™ COUPLER (C-4)

REF #	PART #	DESCRIPTION	QTY.
1	QC-201COM	MALE COUPLER COMPLETE	1
2	QC-1201AS	MALE COUPLER	1
3	HHS0518016	5/16" X 1" BOLT	2
4	QC-6AS	LATCH HANDLE	1
5	HTN0518	5/16" LOCK NUT	2
6	QC-8	LATCH	1
7	QC-12	SPRING	1
8	RLP0500020	5/16" X 1 1/4" ROLL PIN	1
9	QC-3	BOTTOM LATCH PIN	1
10	QC-206AS	LINKAGE PIN	1
11	LF-51	LINKAGE PIN	1
12	DRP0600028	DOUBLE ROLL PIN	1
13	DRP0600032	DOUBLE ROLL PIN	1

NOTE: Qty. shows number of parts received if ordered using listed part numbers.
C-4 is two(QC-201COM) couplers.

TA-76 / TA-77 COSMETICS

REF #	PART #	DESCRIPTION	QTY.
1	DEC-76	DECAL KIT (TA-76)	1
	DEC-77	DECAL KIT (TA-77)	1
2	V-5403-A	RED SPRAY PAINT	1
	V-9524-A	BLACK SPRAY PAINT	1

REF #	PART #	DESCRIPTION	QTY.
3	V-9524-P	PINT BLACK PAINT	1
4	V-9524-Q	QUART BLACK PAINT	1
5	V-9524-G	GALLON BLACK PAINT	1

NOTE: Warning decals are available at no charge. If they become damaged or missing, order part numbers DE-SS1, DE-WLD4-A, DE-WLD5-A, DE-LD1, DE-PP, DE-QCC.

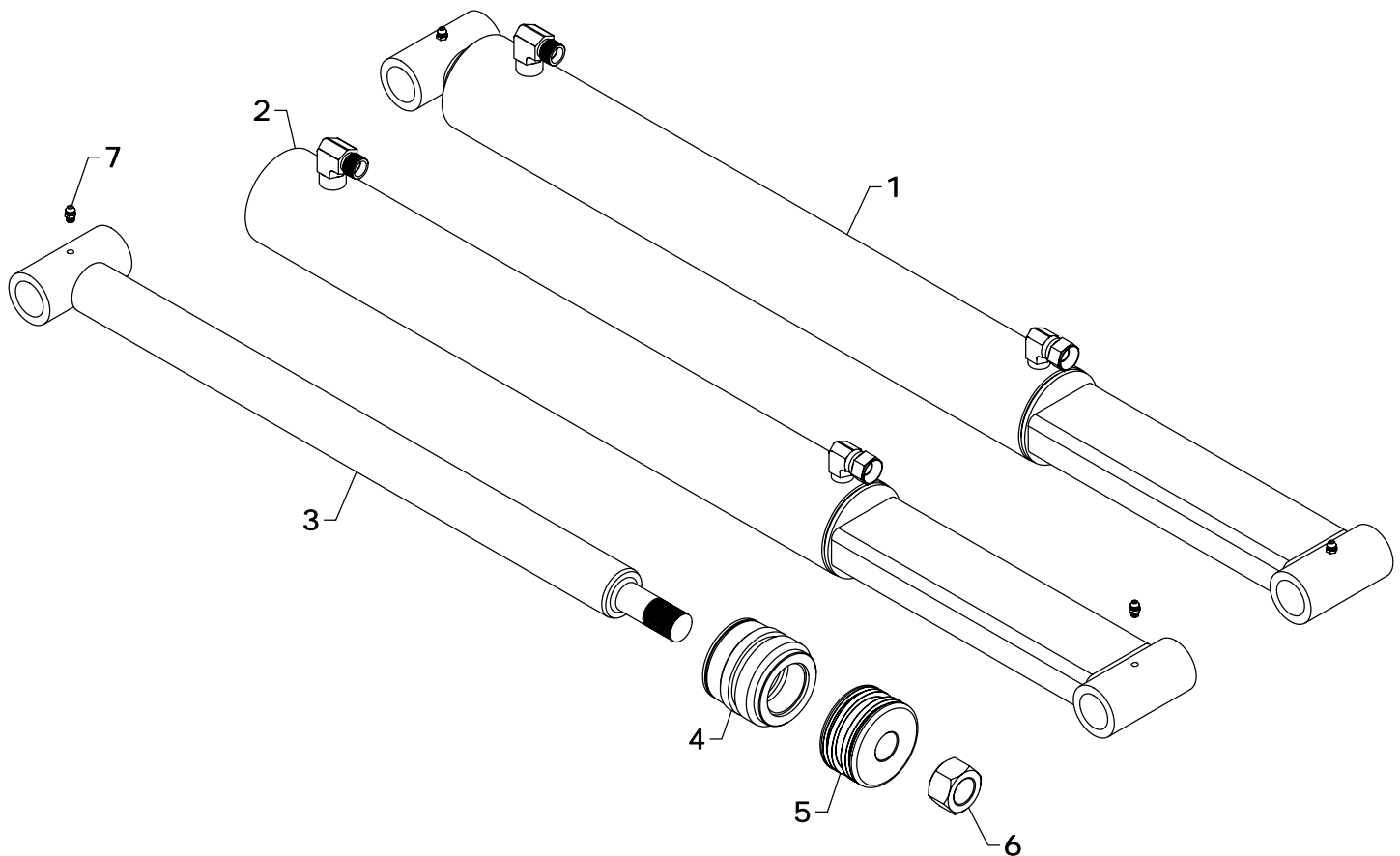

STEPS TO REPAIR CYLINDER

- 1) At the ram end of the cylinder barrel, remove the spiral retaining ring from the top of the gland.
NOTE: The G-E gland does not use the spiral retaining ring.
- 2) Gently drive the gland into the barrel using a brass or non-marring punch until the round retaining ring is visible.
- 3) Remove the round retaining ring using a pair of long nose pliers. Remove the ram assembly (ram, gland, and piston) from the barrel.
- 4) Notice the direction they're pointing so they can be properly re-assembled.
- 5) Remove the jam nut and/or hex nut from the end of the ram.
- 6) Remove the old seals and rings and replace them with the new seals and rings. (Seal kits are packaged for several different cylinders. You may have extra parts)
- 7) Clean cylinder with cleaner and a clean lint free cloth.
- 8) Lubricate the seals and rings to aid assembly.
- 9) Assemble the cylinder by reversing the order.

CYLINDER REPAIR TIPS

- When disassembling cylinders, keep the parts in correct orientation. Remove parts in sequence.
- Note the direction of the piston and gland. Lay out old seals and parts as they are removed.
- Assemble cylinder in proper order; lubricate to aid assembly.

TA-76 / TA-77 BUCKET CYLINDER REPLACEMENT PARTS

REF #	PART #	DESCRIPTION	QTY.
1	B-26	BUCKET CYLINDER	1
2	B-2601	BARREL	1
3	B-2410	RAM	1
4	G-L	GLAND	1
5	P-B	PISTON	1
6	HFN1614	1" NUT	1
7	ZER1805	GREASE FITTING	2
8	#4CK	REPAIR KIT	*

NOTE: * Repair kit contains parts to repair one cylinder

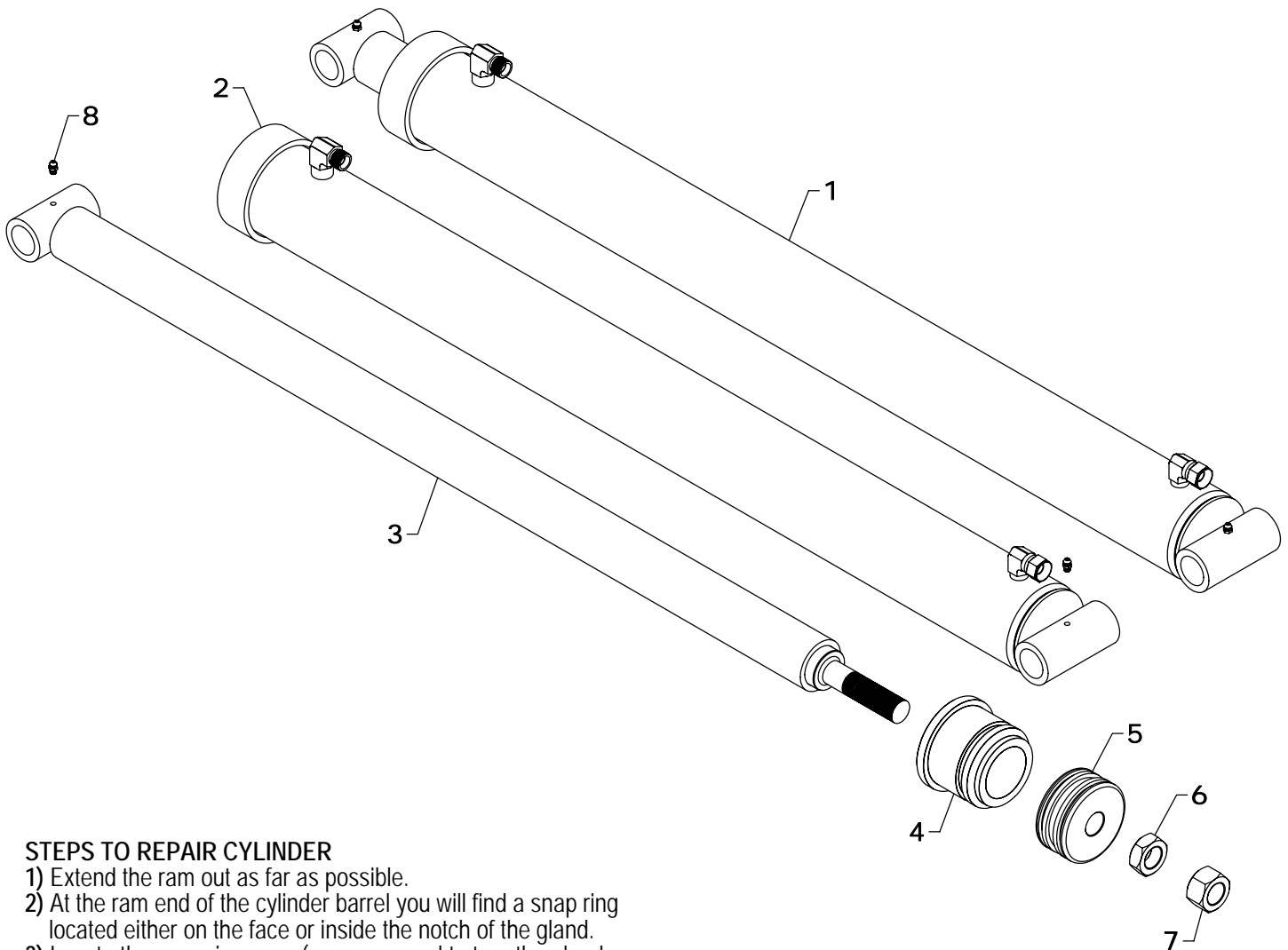

STEPS TO REPAIR CYLINDER

- 1) Extend the ram out as far as possible.
- 2) At the ram end of the cylinder barrel you will find a snap ring located either on the face or inside the notch of the gland.
- 3) Locate the snap ring eyes (you may need to turn the gland inside the barrel to find the snap ring eyes). Compress the snap ring with snap ring pliers.
- 4) Remove the ram assembly (ram, gland, & piston) from barrel.
- 5) Notice the direction they're pointing so they can be properly re-assembled.
- 6) Remove the jam nut and/or hex nut from the end of the ram.
- 7) Remove the old seals and rings and replace them with the new seals and rings. (Seal kits are packaged for several different cylinders. You may have extra parts)
- 8) Clean cylinder with cleaner and a clean lint free cloth.
- 9) Lubricate the seals and rings to aid assembly.
- 10) Assemble the cylinder by reversing the order.

CYLINDER REPAIR TIPS

- When disassembling cylinders, keep the parts in correct orientation. Remove parts in sequence.
- Note the direction of the piston and gland. Lay out old seals and parts as they are removed.
- Assemble cylinder in proper order; lubricate to aid assembly.

TA-77 LIFT CYLINDER REPLACEMENT PARTS

REF #	PART #	DESCRIPTION	QTY.
1	L-29	LIFT CYLINDER	1
2	L-2901	BARREL	1
3	L-1210	RAM	1
4	G-R	GLAND	1
5	P-I	PISTON	1
6	HJN1614	1" JAM NUT	1
7	HFN1614	1" NUT	1
8	ZER1805	GREASE FITTING	2
9	#29CK	SEAL KIT	*

*NOTE: * Repair kit contains parts to repair one cylinder*

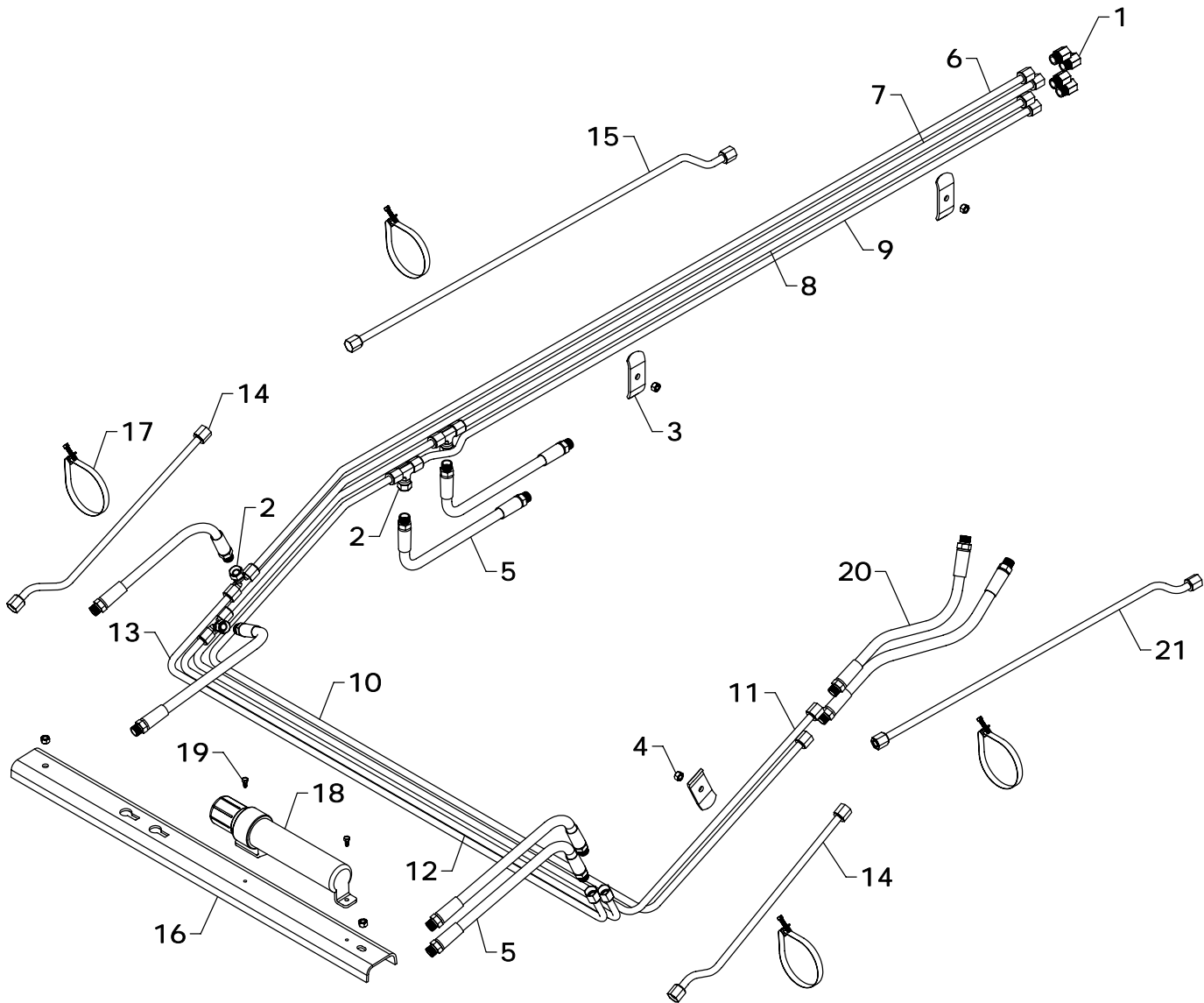

TA-77 HYDRAULICS

REF #	PART #	DESCRIPTION	QTY.
1	PF-FFC8	FEMALE CONNECTOR	4
2	PF-FSBT8	SWIVEL NUT TEE	4
3	OH-3	OIL LINE HOLDER	3
4	HTN0616	3/8" LOCK NUT	5
5	H06020-FF	3/8" X 20" HOSE	7
6	OLT-250	OIL LINE	1
7	OLT-251	OIL LINE	1
8	OLT-252	OIL LINE	1
9	OLT-253	OIL LINE	1
10	OLT-254	OIL LINE	1
11	OLT-255	OIL LINE	1

REF #	PART #	DESCRIPTION	QTY.
12	OLT-166	OIL LINE	1
13	OLT-167	OIL LINE	1
14	OLT-143	OIL LINE	2
15	OLT-3	OIL LINE	1
16	OH-1	OIL LINE PROTECTOR	1
17	BAND-15	METAL BAND	4
18	GP-2	MANUAL CANISTER	1
19	EC-M03	SELF TAPPING SCREW	2
20	H06030-FF	3/8" X 30" HOSE	1
21	OLT-2	OIL LINE	1

WESTENDORFMFG PWB216260

WESTENDORF MFG. CO., INC. • PH: (712) 423-2762 • FAX: (712) 423-1460 • sales@westendorfmfg.com • www.loaders.com