

TA-45 LOADER TOWER REPLACEMENT PARTS

REF #	PART #	DESCRIPTION	QTY.
1	NCT-12AS-(R)	TOWER (RIGHT)	1
2	NCT-12AS-(L)	TOWER (LEFT)	1
--	NAT-120COM - R	SLIDE LOCK COMPLETE (RIGHT)	*
--	NAT-120COM - L	SLIDE LOCK COMPLETE (LEFT)	*
3	NAT-120AS - R	SLIDE LOCK (RIGHT)	1
4	NAT-120AS - L	SLIDE LOCK (LEFT)	1
5	NAT-106 - R	DROP LOCK (RIGHT)	1
6	NAT-106 - L	DROP LOCK (LEFT)	1
7	CBF1011056	5/8" X 3 1/2" CARRIAGE BOLT	4
8	NAT-140	BAR CLAMP BOLT	4

REF #	PART #	DESCRIPTION	QTY.
9	HTN1011	5/8" LOCK NUT	12
10	HHS1011028	5/8" X 1 3/4" BOLT	4
11	HHS1011072	5/8" X 4 1/2" BOLT	4
12	LWM10	5/8" LOCK WASHER	4
13	0H032	FRONT WRAP	**
14	JT-20	PIN	4
15	DRP0600028	DOUBLE ROLL PIN	4
16	RT-15AS	SHOE	2
17	RLG-51	SPRING	2
18	NAT-126	RIVET	2

NOTE: * NAT-120COM - R contains 3, 5, 7(2), 8(2), 9(4), 17, & 18. NAT-120COM - L contains 4, 6, 7(2), 8(2), 9(4), 17 & 18.

** Varies by tractor (Standard Front Wrap is 0H032).

WESTENDORFMFG PWB313290

WESTENDORF MFG CO., INC. • PH: (712) 423-2762 • FAX: (712) 423-1460 • sales@westendorfmfg.com • www.loaders.com

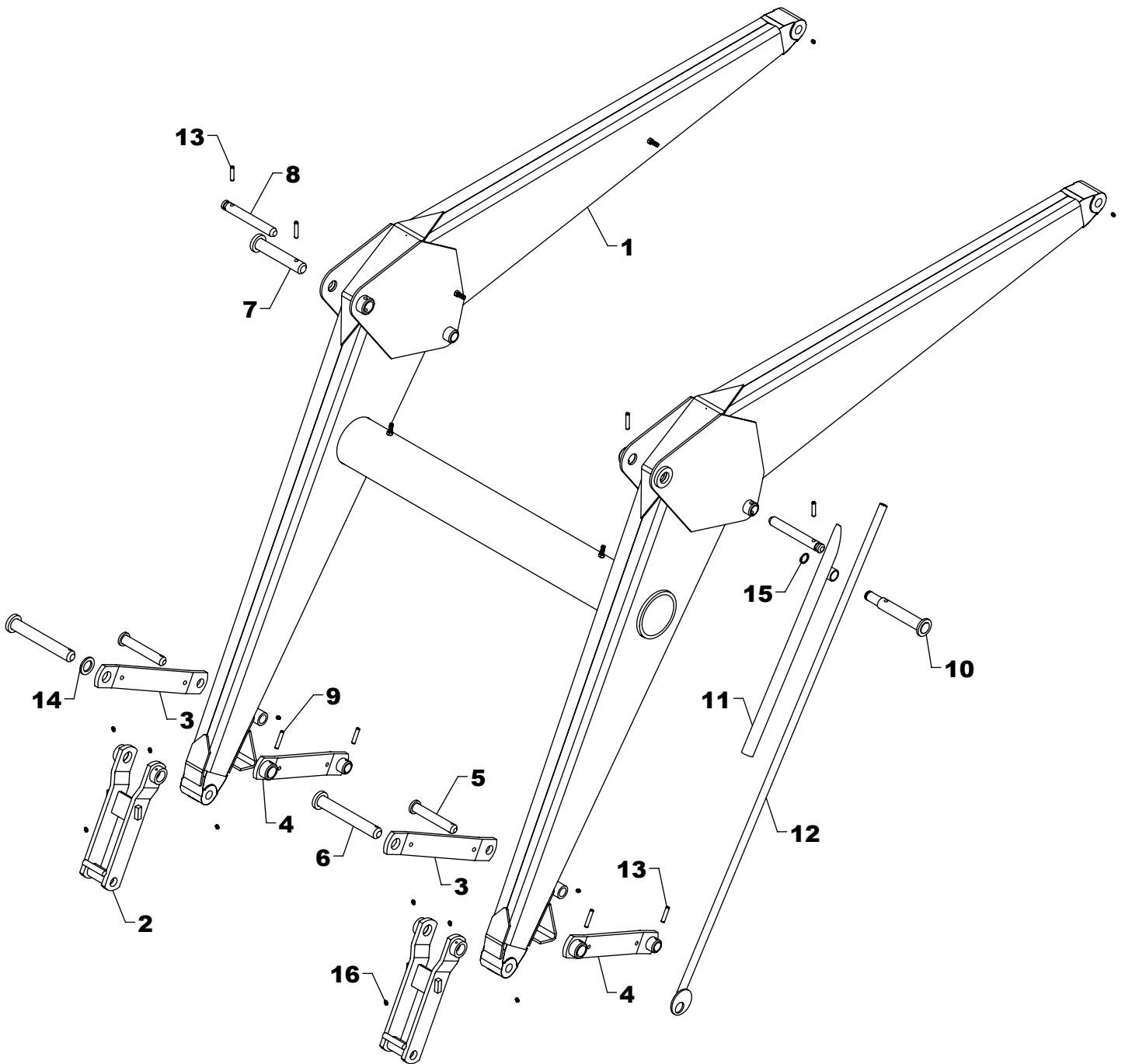

TA-45 LOADER FRAME REPLACEMENT PARTS

REF #	PART #	DESCRIPTION	QTY.
1	NCF-4AS	FRAME	1
2	NAF-15AS	LINKAGE CONNECTOR	2
3	NAF-10	BUCKET PIVOT	2
4	NAF-10AS	BUCKET PIVOT	2
5	LMF-28AS	PIVOT PIN	2
6	LMF-125AS	ROUND HEAD PIN	2
7	NAF-56AS	PIN	1
8	LF-82	LIFT PIN	2

REF #	PART #	DESCRIPTION	QTY.
9	DRP0600032	DOUBLE ROLL PIN	4
10	NAF-57AS	GAUGE ROD PIN S.L.	1
11	LMF-31AS	GAUGE ROD HOLDER	1
12	LMF-47AS	GAUGE ROD	1
13	DRP0600028	DOUBLE ROLL PIN	4
14	NAF-217	SPACER	1
15	SR-C08	SNAP RING	1
16	ZER1805	GREASE FITTING	12

WESTENDORFMFG PWB313290

WESTENDORF MFG. CO., INC. • PH:(712) 423-2762 • FAX: (712) 423-1460 • sales@westendorfmfg.com • www.loaders.com

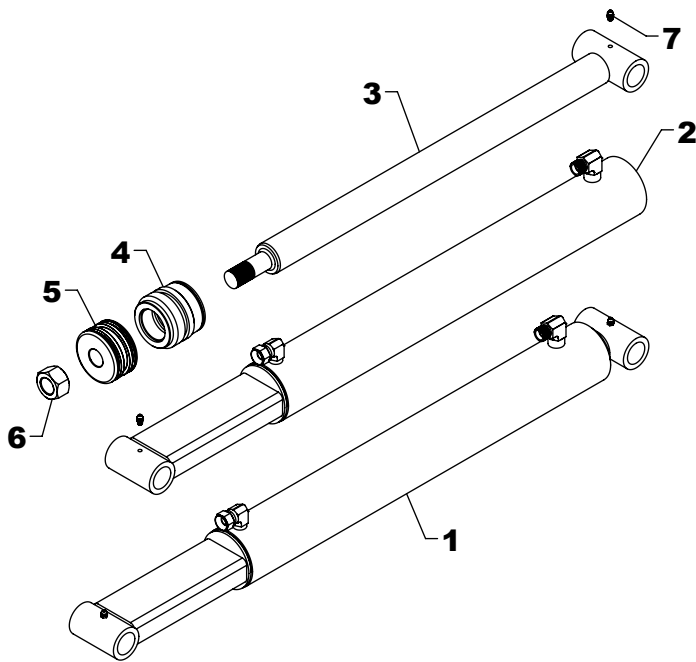

TA-45 / TA-46 / TA-46A BUCKET CYLINDER REPLACEMENT PARTS

REF #	PART #	DESCRIPTION	QTY
1	B-24	BUCKET CYLINDER	1
2	B-2401	BARREL	1
3	B-2410	RAM	1
4	G-L	GLAND	1
5	P-B	PISTON	1
6	HFN1614	1" NUT	1
7	ZER1805	GREASE FITTING	2
8	#4CK	REPAIR KIT	*

NOTE: * Repair kit contains parts to repair one cylinder

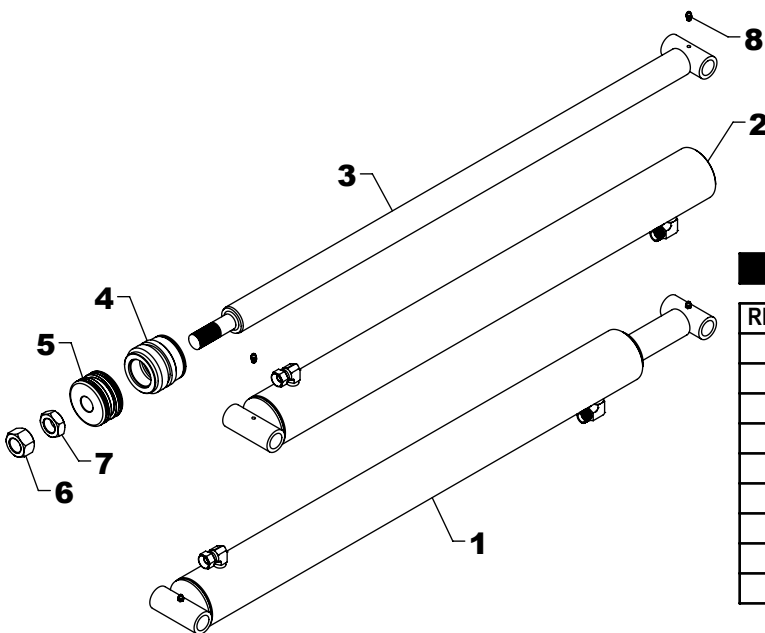

TA-45 LIFT CYLINDER REPLACEMENT PARTS

REF #	PART #	DESCRIPTION	QTY.
1	L-28	LIFT CYLINDER	1
2	L-2801	BARREL	1
3	L-2810	RAM	1
4	G-L	GLAND	1
5	P-B	PISTON	1
6	HFN1614	1" NUT	1
7	HJN1614	1" JAM NUT	1
8	ZER1805	GREASE FITTING	2
9	#4CK	REPAIR KIT	*

NOTE: * Repair kit contains parts to repair one cylinder

STEPS TO REPAIR CYLINDER

- 1) With ram fully extended, remove snap ring or spiral retaining ring from gland at barrel end of cylinder.
 - SNAP RING: Rotate gland until snap ring eyes are visible. Compress with snap ring pliers to remove.
 - RETAINING RING: Gently drive gland into the barrel using a non marring punch to remove retaining ring with a long nose pliers.
- 2) Remove ram assembly (ram, gland, and piston) from barrel.
- 3) Remove piston and gland from ram; be sure to notice the direction they are facing so cylinder can be reassembled properly.

- 4) Remove old seals and rings and replace them with new seals and rings (you may have extra parts as kits are packaged for multiple cylinders).
- 5) Clean cylinder with cleaner and a lint free cloth.
- 6) Lubricate seals and rings and reassemble cylinder in reverse order.

REPAIR TIPS

- Remove parts in sequence and keep in correct orientation during disassembly.
- Notice the direction of piston and gland. Lay out old seals and rings as they are removed.
- Assemble the cylinder in proper order; lubricate to aid assembly.

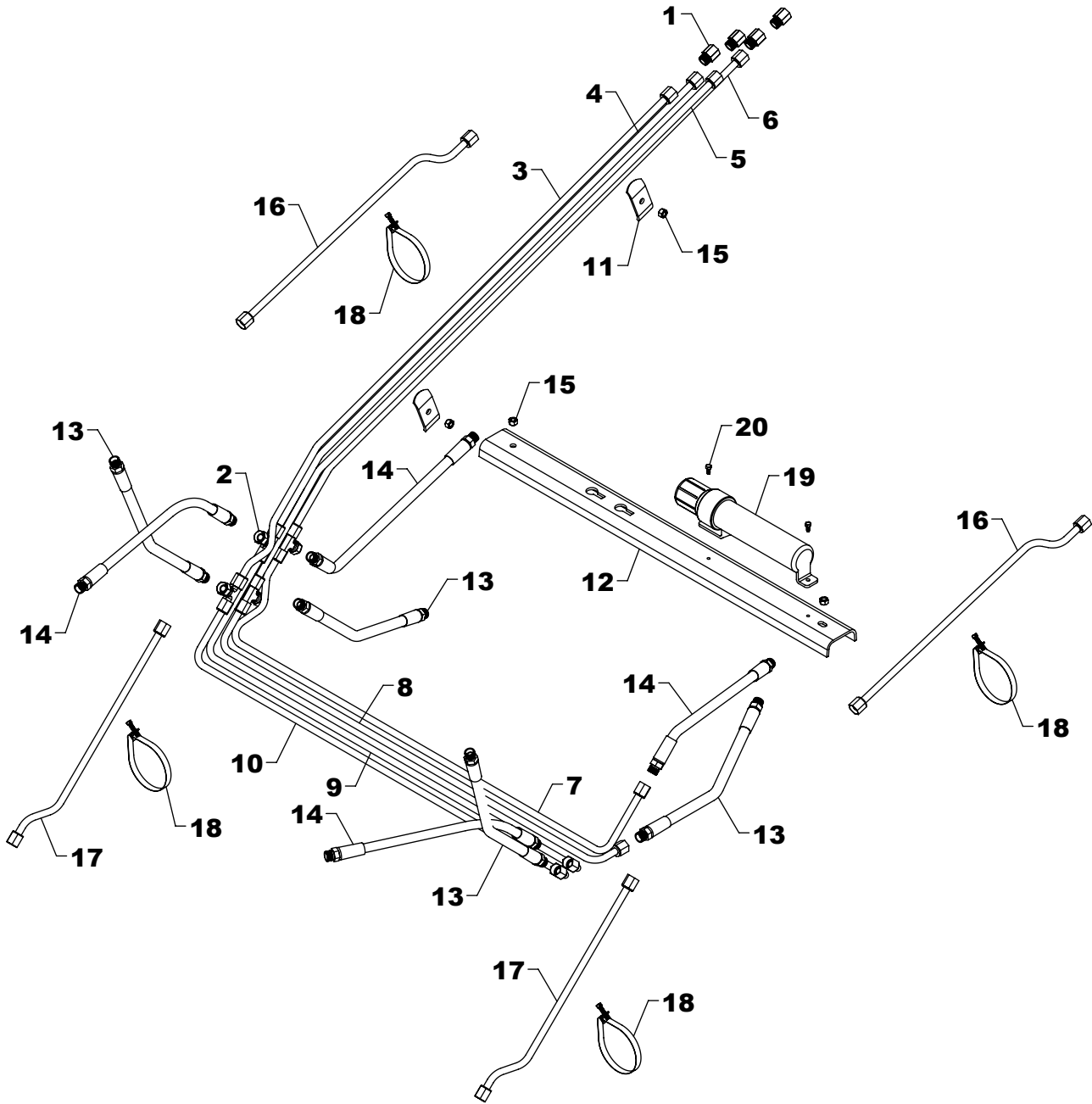

TA-45 HYDRAULICS

REF #	PART #	DESCRIPTION	QTY.
1	PF-FFC8	FEMALE CONNECTOR	4
2	PF-FSBT8	SWIVEL NUT TEE	4
3	OLT-32	OIL LINE	1
4	OLT-33	OIL LINE	1
5	OLT-34	OIL LINE	1
6	OLT-35	OIL LINE	1
7	OLT-36	OIL LINE	1
8	OLT-37	OIL LINE	1
9	OLT-38	OIL LINE	1
10	OLT-39	OIL LINE	1

REF #	PART #	DESCRIPTION	QTY.
11	OH-3	OIL LINE HOLDER	2
12	OH-1	OIL LINE PROTECTOR	1
13	H06015-FF	3/8" X 15" HOSE	4
14	H06020-FF	3/8" X 20" HOSE	4
15	HTN0616	3/8" LOCK NUT	4
16	OLT-1	OIL LINE	2
17	OLT-143	OIL LINE	2
18	BAND-15	METAL BAND	4
19	GP-2	MANUAL CANISTER	1
20	EC-M03	SELF TAPPING SCREW	2

WESTENDORFMFG PWB313290

WESTENDORF MFG. CO., INC. • PH: (712) 423-2762 • FAX: (712) 423-1460 • sales@westendorfmfg.com • www.loaders.com

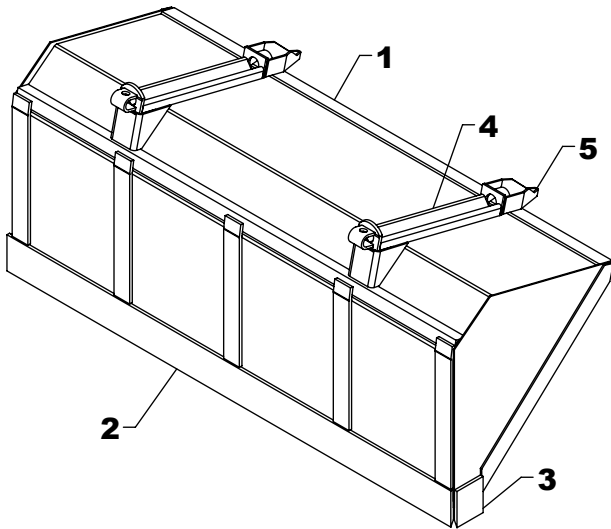

TA-45 / TA-46 TA-46A / TA-48 BUCKET

REF #	PART #	DESCRIPTION	QTY.
1	84Q425	84" BUCKET	1
	90Q425	90" BUCKET	1
	96Q429	96" BUCKET	1
2	SB-14	84" BLADE	1
	LB-14	90" BLADE	1
	CB-14	96" BLADE	1
3	SB-15	BLADE	2
4	QC-13AS	WELD ON ADAPTER	2
5	JB-22	GUIDE (OPTIONAL)	2

NOTE: *Check width of the bucket and use the part number that matches. If your size is not shown, contact Westendorf Mfg. Co.

TA-45 / TA-46 / TA-46A / TA-48 SNAP-ATTACH™ COUPLER (C-4B)

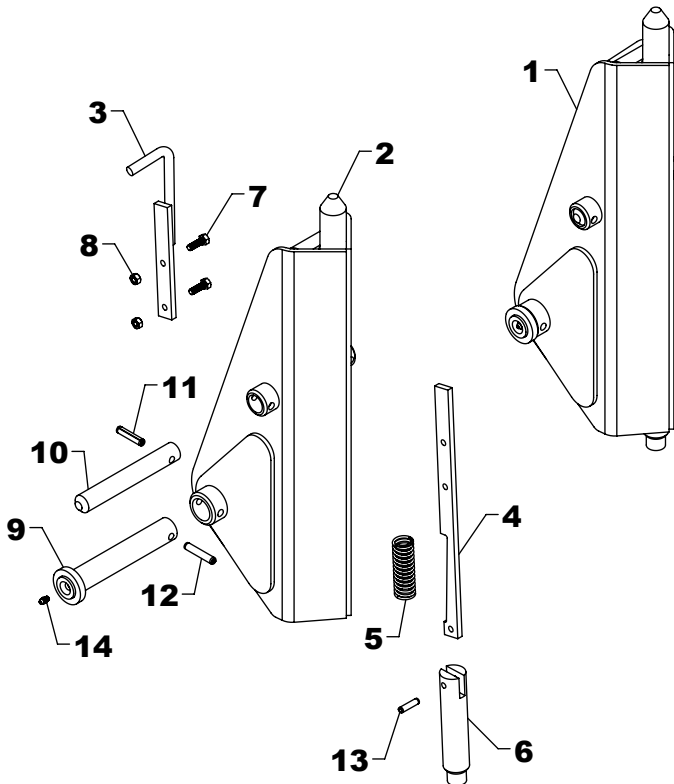

REF #	PART #	DESCRIPTION	QTY
1	QC-1201COM	SNAP ATTACH	1
2	QC-1201AS	MALE COUPLER	1
3	QC-6AS	LATCH HANDLE	1
4	QC-8	LATCH	1
5	QC-12	SPRING	1
6	QC-3	BOTTOM LATCH PIN	1
7	HHS0518016	5/16" X 1" BOLT	2
8	HTN0518	5/16" LOCK NUT	2
9	XAF-55AS	LINKAGE PIN	1
10	LF-51	LINKAGE PIN	1
11	DRP0600028	DOUBLE ROLL PIN	1
12	DRP0600032	DOUBLE ROLL PIN	1
13	RLP0500020	5/16" X 1 1/4" ROLL PIN	1
14	ZER1805	GREASE FITTING	1

NOTE: Qty. shows number of parts received if ordered using listed part numbers.
C-4B is two (QC-1201COM) couplers.

TA-45 / TA-46 / TA-46A / TA-48 COSMETICS

REF #	PART #	DESCRIPTION	QTY.
1	DEC-45	DECAL KIT (TA-45)	1
	DEC-46	DECAL KIT (TA-46 / TA-46A)	1
	DEC-48	DECAL KIT (TA-48)	1
2	V-5403-A	RED SPRAY PAINT	1
	V-9524-A	BLACK SPRAY PAINT	1

REF #	PART #	DESCRIPTION	QTY
3	V-9524-P	PINT BLACK PAINT	1
4	V-9524-Q	QUART BLACK PAINT	1
5	V-9524-G	GALLON BLACK PAINT	1

NOTE: Warning decals are available at no charge. If they become damaged or missing, order part numbers DE-LDI, DE-DWWS, DE-WWWS, DE-TA7, DE-PP, DE-QC, DE-QCC.

WESTENDORFMFG PWB313290

WESTENDORF MFG. CO., INC. • PH: (712) 423-2762 • FAX: (712) 423-1460 • sales@westendorfmfg.com • www.loaders.com