

GF-51 GRAB FORK REPLACEMENT PARTS

Ref.	Part No.	Description	Qty.	Ref.	Part No.	Description	Qty.
1	GF-124AS	LOWER BACK FRAME	1	15	GF-41	10 1/2" PIN	1
2	GF-27AS	TOOTH FRAME	1	16	CTK0400032	1/4" COTTER PIN	4
3	GF-16A	SHAFT	1	17	LF-49A	3 1/2" PIN	1
4	*B-1A	HYDRAULIC CYLINDER	1	18	HHS0616048	3/8" X 3" BOLT	2
5	OLT-143	STEEL OIL LINE	1	19	HTN0616	3/8" LOCK NUT	2
6	BAND-12	METAL BAND	1	20	HM-26	3/4" CLEVIS PIN	1
7	GF-46AS-L	GRAB FORK HOOK (LEFT)	1	21	HAR04	HAIR PIN	1
8	GF-46AS-R	GRAB FORK HOOK (RIGHT)	1	22	GF-35	SHORT TEETH	2
9	GF-48	CENTER CLAMP PLATE	1	23	GF-34AS	LONG TEETH	2
10	HHS1210048	3/4" X 3" BOLT	1	24	PF-FFC8	FLARELESS TO 1/2" NPT	2
11	FWW12	3/4" FLAT WASHER	1	25	HK-21	(1) H060196-86 & (1) H060216-86	1
12	HTN1210	3/4" LOCK NUT	1	**25	HK-27	(2) H06108-86	1
13	HTN1011	5/8" LOCK NUT	8	**26	LM-10	MALE COUPLER	1
14	HHS1011040	5/8" X 2 1/2" BOLT	8	**27	LM-11	FEMALE COUPLER	1

NOTE: *See page 7.3 for B-1A individual parts breakdown. **For GF-51A grab fork.

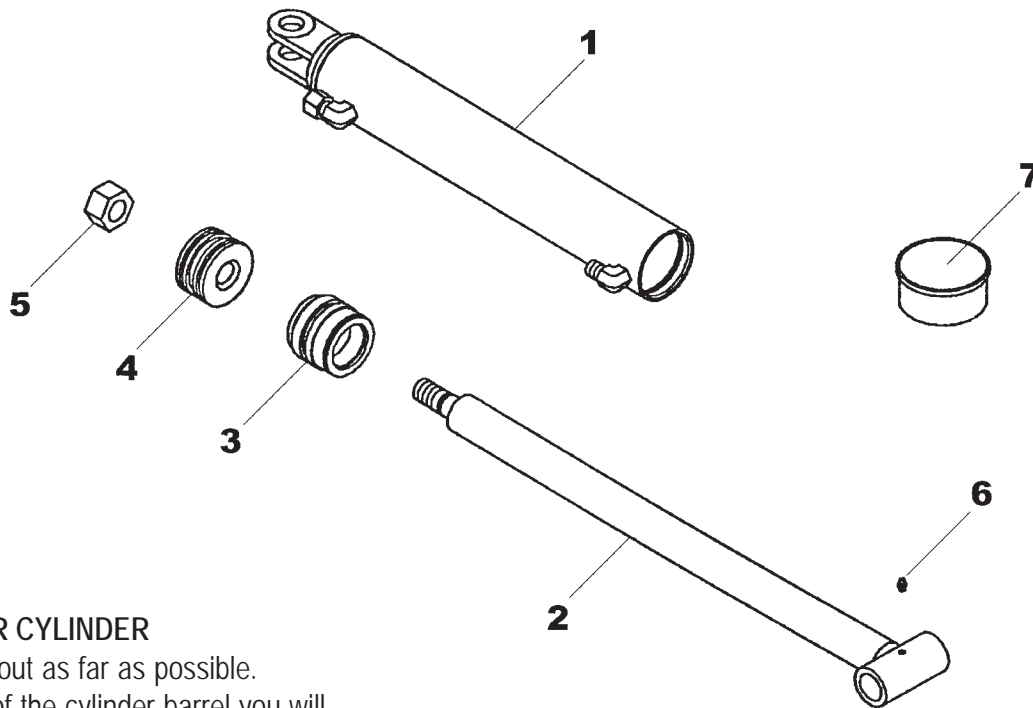

STEPS TO REPAIR CYLINDER

- 1) Extend the ram out as far as possible.
- 2) At the ram end of the cylinder barrel you will find a snap ring located either on the face of the gland or inside the notch of the gland.
- 3) Locate the snap ring eyes (you may need to turn the gland inside the barrel to find the snap ring eyes).
- 4) Compress the snap ring with snap ring pliers.
- 5) Remove the ram assembly (ram, gland, & piston) from barrel.
- 6) Notice the direction they are pointing so they can be properly re-assembled.
- 7) Remove the jam nut and/or hex nut from the end of the ram.
- 8) Remove the old seals and rings and replace them with the new seals and rings. *(Seal kits are packaged for several different cylinders - you may have extra parts.)*
- 9) Clean the cylinder with cleaner and a clean *lint free* cloth.
- 10) Lubricate the seals and rings to aid assembly.
- 11) Assemble the cylinder by reversing the order.

CYLINDER REPAIR TIPS

- When disassembling cylinders, keep the parts in correct orientation. Remove parts in sequence.
- Note the direction of the piston and gland. Lay out old seals and parts as they are removed.
- Assemble cylinder in the proper order; lubricate to aid assembly.

GF-51 GRAB FORK CYLINDER REPLACEMENT PARTS

Ref.	Part No.	Description	Qty.
1	B-101A	CYLINDER BARREL	1
2	B-110	CYLINDER RAM	1
3	G-A	CYLINDER GLAND	1
4	P-A	PISTON	1
5	HFN1614	1" HEX NUT	1
6	ZER1805	GREASE ZERK	1
7	#1CK	SEAL REPAIR KIT	*

NOTE: Seal kit contains parts to repair one cylinder.