

## GF-28 GRAB FORK REPLACEMENT PARTS

Ref.	Part No.	Description	Qty.	Ref.	Part No.	Description	Qty.
1	GF-224AS	LOWER BACK FRAME	1	19	LF-52A	PIN	1
2	HM-26	CLEVIS PIN	1	20	B-1A	HYDRAULIC CYLINDER*	1
3	HAR04	HAIR PIN	3	21	OLT-143	OIL LINE & FITTINGS	1
4	HHS0616048	3/8" X 3" BOLT	2	22	BAND-12	METAL RETAINING BAND	1
5	HTN0616	3/8" LOCK NUT	2	23	PF-FFC8	FLARELESS TO 1/2" NPT	2
6	GF-16A	SHAFT	1	24	GF-225	CLAMP PLATE BRACKET	2
7	LF-49A	3 1/2" PIN	1	25	STP-38	CLAMP PLATE	1
8	CTK0400032	COTTER PIN	2	26	HHS1011032	5/8" X 2" BOLT	2
9	GF-127AS	TEETH FRAME	1	27	GF-46AS-R	RIGHT BUCKET HOOK	1
10	GF-135	OUTSIDE TOOTH	2	28	GF-46-AS-L	LEFT BUCKET HOOK	1
11	GF-134	INSIDE TOOTH	2	29	GF-48	CLAMP PLATE	1
12	GF-137A	ADJUSTABLE TOOTH	2	30	HHS1210048	3/4" X 3" BOLT	1
13	HHS1011040	5/8" X 2 1/2" BOLT	8	31	FWW12	3/4" FLAT WASHER	1
14	HTN1011	5/8" LOCK NUT	14	32	HTN1210	3/4" NUT	1
15	GF151AS	SPACER TUBE	1	33	HK-21	1-H06196-86 & 1-H06216-86	1
16	GF-150	THREADED ROD	1	33	HK-27	2-H06108-86**	1
17	ET-38A	CLEVIS PIN	2	34	LM-10	MALE COUPLER**	1
18	DRP0600028	DOUBLE ROLL PIN	1	35	LM-11	FEMALE COUPLER**	1

NOTE: \*See page 7.3 for B-1A individual parts breakdown. \*\*For GF-28A grab fork.

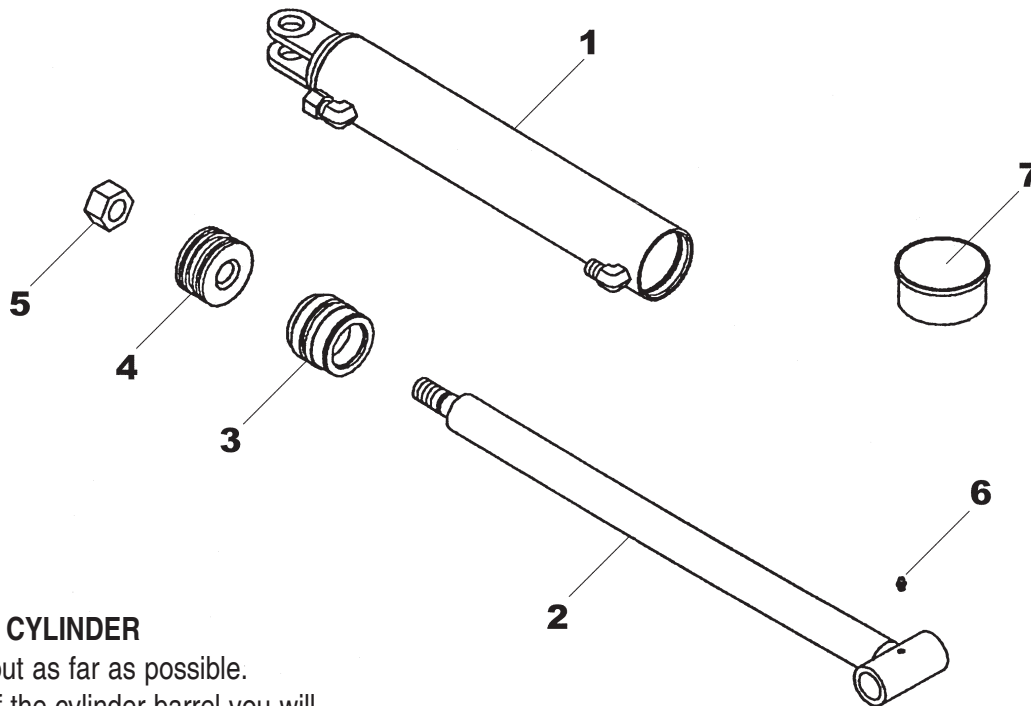

## STEPS TO REPAIR CYLINDER

- 1) Extend the ram out as far as possible.
- 2) At the ram end of the cylinder barrel you will find a snap ring located either on the face of the gland or inside the notch of the gland.
- 3) Locate the snap ring eyes (you may need to turn the gland inside the barrel to find the snap ring eyes).
- 4) Compress the snap ring with snap ring pliers.
- 5) Remove the ram assembly (ram, gland, & piston) from barrel.
- 6) Notice the direction they are pointing so they can be properly re-assembled.
- 7) Remove the jam nut and/or hex nut from the end of the ram.
- 8) Remove the old seals and rings and replace them with the new seals and rings. (*Seal kits are packaged for several different cylinders - you may have extra parts.*)
- 9) Clean the cylinder with cleaner and a clean **lint free** cloth.
- 10) Lubricate the seals and rings to aid assembly.
- 11) Assemble the cylinder by reversing the order.

## CYLINDER REPAIR TIPS

- When disassembling cylinders, keep the parts in correct orientation. Remove parts in sequence.
- Note the direction of the piston and gland. Lay out old seals and parts as they are removed.
- Assemble cylinder in the proper order; lubricate to aid assembly.

## GF-28 GRAB FORK CYLINDER REPLACEMENT PARTS

Ref.	Part No.	Description	Qty.
1	B-101A	CYLINDER BARREL	1
2	B-110	CYLINDER RAM	1
3	G-A	CYLINDER GLAND	1
4	P-A	PISTON	1
5	HFN1614	1" HEX NUT	1
6	ZER1805	GREASE ZERK	1
7	#1CK	SEAL REPAIR KIT	*

**NOTE:** Seal kit contains parts to repair one cylinder.