

XTA-700

SPECIFICATIONS

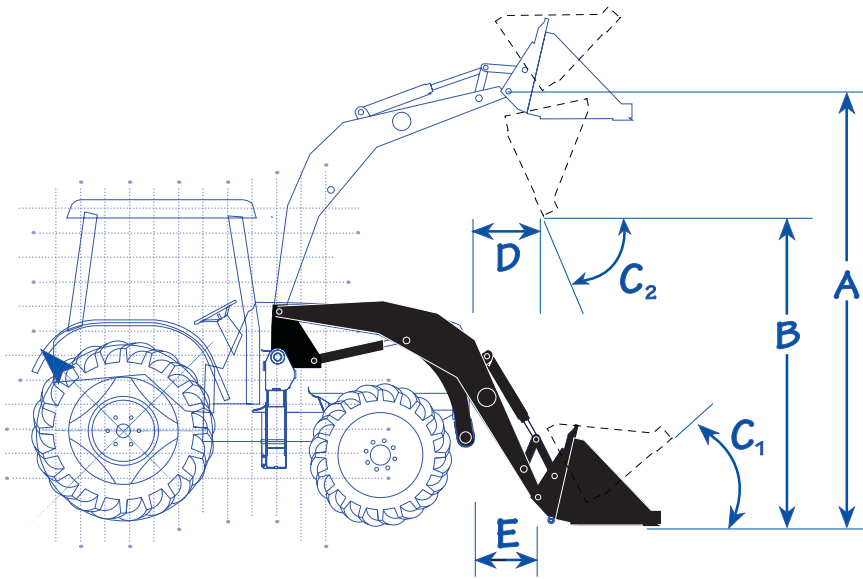

- A) Lift Height: **180" - 15'**
- B) Clearance: **141" - 11'9"**
- C) Bucket Roll Back Angle: **34°**
Bucket Dump Angle: **47°**
- D) Reach at Max Height: **31"**
- E) Reach at Ground Level: **32"**

	2500 PSI	3000 PSI
Lift Capacity - AWC* <small>(31.5" forward from pin)</small>	6200	7440
Lift Capacity - Pivot Pin	9080	10900

*AWC - Actual Working Capacity

PACKAGE COMPONENTS

- Hydraulic Power-Mount™
- Snap-Attach™
- Hose Kit
- Standard Bracket Set
- MA-280 Hydra-Snap™ Hydraulic Manifold
- Bucket Gauge Rod
- Full Range Level Indicator
- 3-1/2" Lift Cylinders
- 3" Bucket Cylinders
- 96" Large Capacity Bucket
- 108" Large Capacity Bucket (opt)

LOADER SPECIFIC UPGRADES & ATTACHMENTS

Loader Upgrades

- Mechanical Self-Leveling
- 3rd Steel Line
- Back Drag Blade
- Rotational Indicators
- Hydra-Snap™ Manifold
- Level UP Advantage
- Comfort Ride

HDHC-Heavy Duty High Capacity Buckets

- 84" HDHC Double Weld-On Blade
- 84" HDHC Bolt-On Blade
- 96" HDHC Double Weld-On Blade
- 96" HDHC Bolt-On Blade

Speciality Buckets

- High Volume Low Density Bucket
- Feed Bunk Bucket

- Z-47 Feeder Bucket
- Fork Bucket
- Tine Bucket

Attachments - Material Handling

- Brush Crusher™
- Brush Crusher™ Finishing Teeth
- 84" Bucket Teeth 84" & 96" Buckets
- Rake Teeth
- Sabretooth
- Monster Grab Fork
- Quick Mount Claw Grab Fork
- 84" Cat Claw 3-D Grab Fork
- 96" Cat Claw 3-D Grab Fork
- 42" Fork Lift
- 48" Fork Lift
- Extendable Boom

Attachments - Hay Handling

- 2-Prong Bale Spear
- 3-Prong Bale Spear
- 4-Prong Bale Spear
- Stack Saver I & II
- Bale Handler
- Bale Grab
- Squeezer™

Additional Attachments

- 84"-120" Dozer Blade
- 96"-120" Snow Scraper
- 96" V-Plow
- Dual Changer Max for bucket
- Snap-Attach™ Adapters - Set (2)
- Snap-Attach™ Synchronizer



WESTENDORF MANUFACTURING CO. INC.

P.O. BOX 29 • ONAWA, IA 51040 • PH: (712) 423-2762 • FAX: (712) 423-1460
Email: sales@westendorfmfg.com Website: www.loaders.com