

TA-160

SPECIFICATIONS

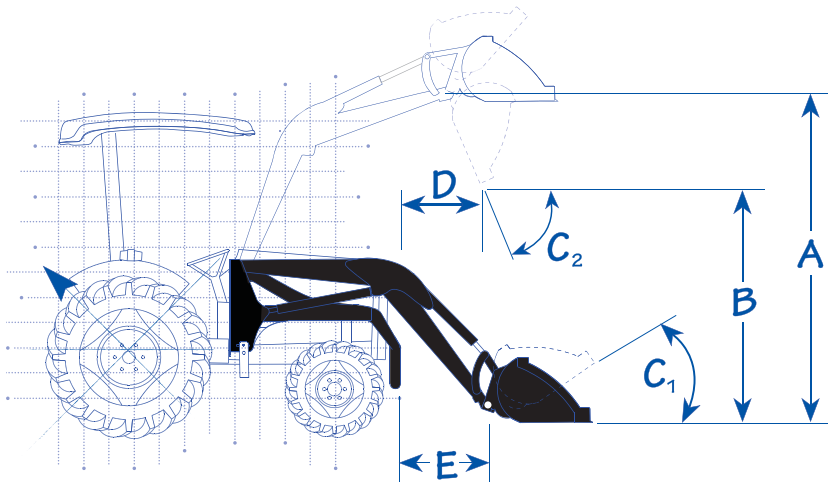

- A) Lift Height: **113" - 9'5"**
- B) Clearance: **96" - 8'**
- C) Bucket Roll Back Angle: **30°**
Bucket Dump Angle: **31°**
- D) Reach at Max Height: **33"**
- E) Reach at Ground Level: **20"**

	1800 PSI	2200 PSI
Lift Capacity - AWC* <small>(31.5" forward from pin)</small>	1650	2020
Lift Capacity - Pivot Pin	2210	2700

*AWC - Actual Working Capacity

PACKAGE COMPONENTS

- Hydraulic Power-Mount™
- Quick-Attach System
- Hose Kit
- Standard Bracket Set
- One Lever Joystick with Valve and Manifold Kit
- Bucket Gauge Rod
- 2" Lift & Bucket Cylinders
- 60" Tapered Bucket
- 66" Tapered Bucket (opt)
- 60"-66" Skid Steer Buckets and Adapter (opt)

LOADER SPECIFIC UPGRADES & ATTACHMENTS

Loader Upgrades

- Hydra-Snap™
- Hydraulic Valve Block
- Comfort Ride
- Power Beyond
- 3-Prong Bale Spear
- 60" Bucket Teeth
- 60" Dozer Blade
- 72" Snow Scraper
- 72" V-Plow
- Ballast 3 Pt. Barrel Holder
- Forklift with 42" Teeth
- Brush Crusher™
- Brush Crusher™ Finishing Teeth



WESTENDORF MANUFACTURING CO. INC.

P.O. BOX 29 • ONAWA, IA 51040 • PH: (712)423-2762 • FAX:(712)423-1460
Email: sales@westendorfmfg.com Website: www.loaders.com