

"THE LOADER SPECIALISTS" » 100 SERIES

100 SERIES LOADER SHOWN ON CASE 2WD TRACTOR. FEATURES QUICK CHANGE BALE SPEAR ATTACHMENT. FIND MORE LIFT AND CARRY ATTACHMENTS SUCH AS BOOM, THRIFTY LIFT, SCISSORS LIFT, AND HIGH LIFTER IN ATTACHMENT SECTION.

“The size of the loader, construction and weight of the loader fit the 40-50 horsepower tractor; it is a nice loader. It works fast, good and the quick attach bucket is nice. The joystick valve is what the younger generation wants. It's a good price for what it is. I got one of the first ones Westendorf made and have done a lot of hard work with it.”

**Leamon Donegan** - Tennessee



# 100 Series

Our Mini to Mid-Sized high strength loader series; its got you covered. Designed to fit tractors up to 90 HP. It's the perfect loader for your two or four wheel drive compact tractor. The 100 Series turns any compact tractor into a real workhorse. The patented design puts quality, strength, good looks and ease of handling into a loader that makes work fun. You're going to love the new precision fingertip control hydraulic Power-Mount™ to free up your tractor for other uses without having your loader in the way. The smart bucket design is made to clean out quickly; the amazing low-profile design gives you great visibility, and the power linkage gives you great rollback and dump angles. The list goes on and on. Select from a complete lineup of attachments that are practical, functional and look excellent on your tractor.



# Mini-Matic 100 Series loaders

-- developed with "big" loader performance

Just because this line of loaders is designed for the compact tractor, doesn't mean it won't pack a punch or offer the same time-saving benefits as a "big" loader. Westendorf maintains the legendary power and user-friendly focus in this smaller line of loaders.

It makes no sense getting a loader if it isn't going to do what you need it to do.

### Payload is what matters

Lift capacity, especially in a compact loader, is an important criteria when selecting the right loader for the tasks at hand. A double tapered arm design allows two very important benefits. First, it adds tremendous strength to the loader to resist side-to-side pressures; and second, it results in a lighter weight design which allows you to lift more payload

safely while staying within your tractor's front axle rating.



### Power-Mount™ - It's on when you need it and off when you don't

When its time to mow, just park your loader in minutes with Westendorf's Power-Mount™ system. Others "say" theirs is easy, but none match the speed, ease and simplicity of this all-matic hydraulic system. Power-Mount™ does NOT require tools or dangerous stands and can be on OR off in less than 2 minutes.

### It's the little things that matter

We've covered a couple of the big things that matter when choosing a loader, now for the little things. It's our attention to detail that you'll appreciate every time you use your loader.

- Reliable quick-attach bucket systems
- Valve and joystick packages
- Hydra-Snap™ one-lever manifold connects "all" hoses in one motion
- Gauge rod to monitor the load
- Smart bucket design cleans out fast
- Professionally engineered brackets for low-profile fit & increased visibility
- Largest selection of innovative material handling attachments ensure you'll get a reliable loader that will get the job done and hold its value over time.



### It's quick!

Of course, the 100 Series\* loaders come with the time-tested and patented Quick-Attach system. That saves you time and money, and that's what Westendorf is all about.

\*TA-52 & TA-55 available with pin type bucket.

### Power-Linkage

What does power-linkage mean to you? It means you will have all the power you need and more to get the job done right without hassles of material spilling off the front edge of the bucket.

### More Attachments

Choose from a wide selection of 100 Series attachments—more options than any other loader in its class on the market today.



### Westendorf is Looking out for you

The superior fit of the Westendorf low-profile design keeps the loader out of your field of vision so you can see where you are going. Our tailor fit mounting brackets position the loader in the best possible position, keeping the bucket close to the front axle for additional stability and power.

### Simple mounting system

Since Westendorf loaders fit many 2WD and 4WD tractor lines, they provide the highest resale value in the industry. This versatility allows you to use the same loader on several different tractors. The simplicity and speed of the Power-Mount™ system lets you take your loader off or put it on in just minutes without any tools or dangerous stands.



### It's all about precision

The precision joystick gives you the kind of fingertip control that you can only dream about. Its adjustable bracket is designed for operator comfort. The in-line valve allows clean, quick and compact installation; plus, the quick connectors are color coded for simple identification.



### Clean open bucket

Patented bucket design is tapered on all sides and has a rib-free interior for quick release of materials. It's tapered like an ice cube tray so snow and other materials that typically tend to stick will release easily.



### Reach new heights

100 Series loaders have incredible lifting power and amazing lift heights (up to 11') in a small, good-looking package. You stack whatever you have, wherever you want it in one smooth motion.

### Quality Cylinders

Westendorf cylinders are manufactured to internal quality levels based on over 75 years experience. Metal piston rings and chrome-plated piston rods add more protection from rust corrosion and stroke wear.



Cool Cap™ Tractor shade canopies...p. 126



# Results

We deliver the best overall customer-driven results with the most power and highest lift in the industry.



There is nothing that has served me better or as well as this front-end loader.

"My TA-111 loader is absolutely amazing. It has saved me hours of work. You can't believe the size of rocks this loader can lift. It even moved a telephone pole with a glob of cement block on it. I can move 7 or 8 poles at one time. There is nothing that has served me better or as well as this front-end loader. The quality and construction of this TA-111 certainly outdoes all others."

Gordon Arteno - Tennessee

### Easy handling

Tailor fit brackets and patented loader design make it possible to position the loader and bucket back on the tractor providing added stability and balanced weight distribution to enhance the overall feel, performance and handling.

### Custom options

Build a loader package to meet your material handling needs. Add items such as:

- Hydra-Snap one lever coupling manifold
- Skid-steer adapter plate
- Comfort Ride
- Custom tractor matching paint





Shown with Brush Crusher  
more attachments...PP. 26 & 104



## TA-52

**Small package  
with plenty of muscle**

10-24 HP »  
1350#+ at 6'1"

The TA-52 is the ideal fit for smaller tractors and lawn mowers. It is an economical loader that has two strong bucket cylinders for more power than comparable loaders with a single bucket cylinder. It is a sturdy compact loader for the rural homeowner who wants to move snow, dirt, pick up materials such as brush, move small bales, clean out stables, landscape and more. Its excellent lift height for its size can load into a pickup or trailer. The extra-wide sub-frame increases visibility while working and accommodates side-mount mufflers.

**TA-52 Base package:**

- 1-3/4" Bucket Cylinder
- 1-1/2" Lift Cylinder
- Hydraulic Power-Mount™
- Mounting & Hose Kit
- Regen Valve & Joystick Package
- Bucket Gauge Rod
- 48" Bucket

**Options:**

- 54" Bucket
- Bucket Teeth
- Hydra-Snap™
- Comfort Ride
- Attachments (pp. 26-27)

## TA-55

**Right size  
with higher lift**

10-24 HP »  
1150# at 7'2"

The TA-55 is the economical loader for the rural homeowner. It has good clearance for easy maintenance. Quickly move snow or dirt, pick up trash, load pickups, haul feed or small bales, spread gravel and sand, clean horse stables and more. The ideal loader for snow removal and material handling around the yard. The loader has excellent visibility with extra-wide sub-frame to accommodate side-mount mufflers.

**TA-55 Base package:**

- 1-3/4" Bucket Cylinder
- 1-1/2" Lift Cylinder
- Hydraulic Power-Mount™
- Mounting & Hose Kit
- Regen Valve & Joystick Package
- Bucket Gauge Rod
- 48" Bucket

**Options:**

- 54" Bucket
- Bucket Teeth
- Hydra-Snap™
- Comfort Ride
- Attachments (pp. 26-27)



“ I received my BC-3000's last Friday, I can't begin to tell you how useful a tool they are. I was able to cut a large quantity of fire wood in a short amount of time and the size of the logs I was lifting was amazing. I am very happy with my purchase. I found myself looking around to see what else I could lift.

**Tom Murgo** - Rhode Island

NEW - Snow Scraper in  
5' & 6' widths...pp. 108-109



# Versatile

## TA-111

**The ultimate compact loader**

17-35 HP »  
2300# at 8'3"

The TA-111 provides the full features of the larger Westendorf in a smaller package. Complete with low-profile design and quick-attach bucket. Works with belly mounted mowers and has an adjustable front wrap to allow a 6" adjustment up & down or front and back. Nearly 300 fits for old or new tractor models. It is a great chore loader and is excellent for material handling and snow removal.

**TA-111 Base package:**

- 2" Bucket & Lift Cylinders
- Hydraulic Power-Mount™
- Mounting & Hose Kit
- Precision Valve w/ Regen Spool
- Precision Joystick
- Bucket Gauge Rod
- 60" Bucket

**Options:**

- Skid-Steer Adapter & Buckets
- Bucket Teeth
- Hydra-Snap™
- Comfort Ride
- Attachments (pp. 26-27)

## TA-140

**The "Boomer" Buddy**

2WD 15-35 HP »  
4WD 15-30 HP »  
2300# at 7'7"

Turn your compact tractor into a real workhorse. This beauty is designed for horse owners, acreage owners, or anyone who needs the power to move things fast and easy. Uniquely designed to match your super steer's turning radius, this tractor will always look its best with Westendorf's clean bracket design. It works with most belly mounted mowers and has a complete line of attachments.

**TA-140 Base package: Options:**

- 2" Bucket & Lift Cylinders
- Hydraulic Power-Mount™
- Quick Attach
- Mounting & Hose Kit
- Bucket Gauge Rod
- 60" Bucket
- Skid-Steer Adapter & Buckets
- Bucket Teeth
- Hydra-Snap™
- Comfort Ride
- Attachments (pp. 26-27)



**A** - The ideal compliment to the power-mount system, the Hydra-Snap makes connecting or disconnecting the loader to the tractor a breeze. Keep your hands clean, and don't worry about mixing up hoses any more. This patented time-saving upgrade is available on ANY 100 Series loader. Just rotate the lever and ALL hoses couple at once.





Cool Cap™ Easy-Off Mounting Bracket...p.126

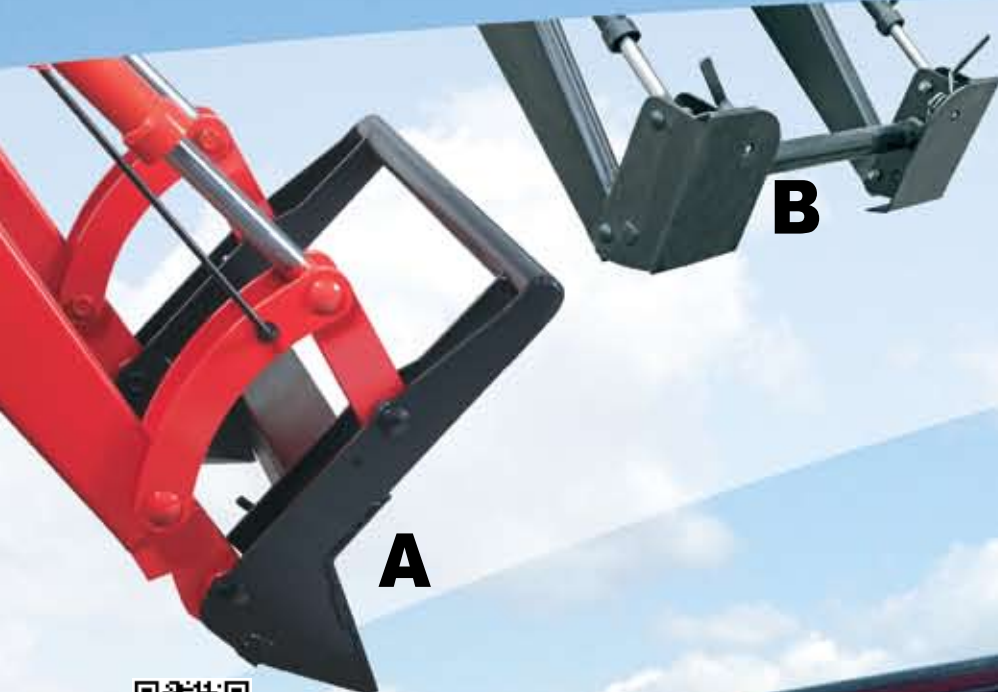

**A**

**A** - A quick-attach system turns your loader into a user-friendly, multi-purpose tool. Removing the bucket is quick and easy. Change to another attachment in just minutes.



**B**

**B** - You have a skid steer and loader. Why not share attachments? New adapters are now available from Westendorf to convert the TA-111, TA-140, TA-160, TA-170, and TA-180 to be skid steer compatible.



## TA-160

**Incredible Lifting Power**

2WD 20-60 HP »  
4WD 20-50 HP »  
2700# at 9'5"

The TA-160 is a smooth-shaped loader designed for the serious weekender that needs to handle large round bales. It has incredible lifting power in a small, good-looking package. Scooping snow, moving hay, performing dirt work or unloading pallets, this beauty is ready to work. Features an open tapered bucket for quick clean out, clean bracket design for better tire clearance and low-profile fit to let you see clearly what you are doing and where you are driving.

### TA-160 Base package:

- 2" Bucket & Lift Cylinders
- Hydraulic Power-Mount™
- Quick Attach
- Mounting & Hose Kit
- Precision Valve w/ Regen Spool
- Precision Joystick
- Bucket Gauge Rod
- 60" Bucket

### Options:

- 66" Bucket
- Skid-Steer Adapter & Buckets
- Bucket Teeth
- Hydra-Snap™
- Comfort Ride
- Attachments (pp. 26-27)



*It Really IS This Easy!*

Mount or dismount your loader in less than 2 minutes without the use of tools or dangerous kick stands. Is it time to mow? Just back out of your loader to free your tractor for the task at hand.

# TA-170

2WD 20-70 HP »  
4WD 20-65 HP »  
2380# at 10'2"

## More loader with lots of Extras

This mid-sized, high-strength loader has a great profile. It is for the everyday heavy user or contractor. Extra features give it a professional feel and performance, low-profile, power linkage, tapered bucket, cushioned spring ride, reinforced arms, and clean bracket design for excellent visibility and tire clearance. Experience precision like never before with the ergonomically designed precision joystick and valve, which comes standard in the loader package, along with all hoses and mounting brackets.

- |                                 |                                |
|---------------------------------|--------------------------------|
| <b>TA-170 Base package:</b>     | <b>Options:</b>                |
| • 2" Lift & Bucket Cylinders    | • 66" & 72" Std. Buckets       |
| • Hydraulic Power-Mount™        | • Lift Cylinder Upgrade        |
| • Quick-Attach                  | • Skid-Steer Adapter           |
| • Mounting & Hose Kit           | • 66" & 72" Skid Steer Buckets |
| • Precision Valve w/Regen Spool | • Bucket Teeth                 |
| • Precision Joystick            | • Hydra-Snap™                  |
| • Bucket Gauge Rod              | • Comfort Ride                 |
| • 60" Bucket                    | • Attachments (pp. 26-27)      |



# Powerful

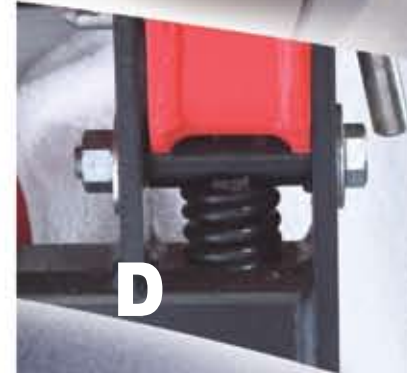

A

B

C

D

**A** - Experience precision like never before with the precision valve and cable joystick. It gives you the kind of fingertip control you've been dreaming about. The adjustable mounting bracket has been carefully designed (either fender mount or floor mount) for maximum operator ease so the ergonomic handle design fits comfortably in the palm of your hand.

**B** - A loader with a superior fit that follows the hood will feel better and will allow you to see more clearly while working. It will eliminate tunnel vision and promote a faster, safer working environment.

**C** - The clean open bucket is tapered on all sides and has a rib-free interior for quick release of materials. It's tapered like an ice cube tray so snow and other materials that tend to stick will release easily.

**D** - Get a cushioned, quiet ride when driving with the loader mounted on the tractor. (TA-170 & 175)

# TA-175

Loaded with power and features

2WD 20-70 HP »  
4WD 20-65 HP »  
3690# at 10'2"

Ideal for the everyday heavy user, dirt work or hay handler. The TA-175 offers all the same features as the TA-170 plus more capacity. Share implements between your skid-steer and loader as the TA-175 includes the universal skid-steer adapter. It's a smooth operating loader with low-profile fit for good visibility. Excellent dump and rollback angles, smart bucket for quick clean out, cushioned ride, reinforced arms, clean bracket design, and precision valve and joystick included with the loader package.

## TA-175 Base package:

- 2" Bucket Cylinders
- 2-1/2" Lift Cylinders
- Hydraulic Power-Mount™
- Skid-Steer Quick-Attach
- Mounting & Hose Kit
- Precision Valve w/Regen Spool
- Precision Joystick
- Bucket Gauge Rod
- 72" Skid Steer Bucket

- Options:**
- Hydra-Snap™
  - Comfort Ride
  - Attachments (pp. 26-27)

# TA-180

Reaching amazing new heights

2WD 20-90 HP »  
4WD 20-80 HP »  
4725# at 11'

The TA-180 has an incredible lift height of 11 feet with a low-profile fit. Think about it! You can stack whatever you have, wherever you want it. Plus, when you combine it with the famous Quick-Attach System, you can change from your bucket to a spear, forklift, or other attachment in just minutes to take on any task at hand.

- |  |  |
|--|--|
| <b>TA-180 Base package:</b>  | <b>Options:</b>  |
| <ul style="list-style-type: none"> <li>• 2-1/2" Bucket &amp; Lift Cylinders</li> <li>• Hydraulic Power-Mount™</li> <li>• Quick-Attach</li> <li>• Mounting &amp; Hose Kit</li> <li>• Precision Valve w/Regen Spool</li> <li>• Precision Joystick</li> <li>• Bucket Gauge Rod</li> <li>• 60" Bucket</li> </ul> | <ul style="list-style-type: none"> <li>• 66" or 72" Std. Buckets</li> <li>• Skid-Steer Adapter</li> <li>• 66" or 72" Skid-Steer Buckets</li> <li>• Bucket Teeth</li> <li>• Hydra-Snap™</li> <li>• Comfort Ride</li> <li>• Attachments (pp. 26-27)</li> </ul> |



# Professional

We deliver professional customer-driven results; paired with our time-tested and grandfather approved Power-Mount™ system, you'll have the most adaptable material handling system available on the market today.

**A** - The TA-185 features exclusive "smart pac" cylinders with swaged ends that automatically compress the gland and its packings past the edge of the barrel during assembly for quality controlled consistency every time.

**B** - Get a cushioned, quiet ride when driving with the loader mounted on the tractor. (TA-180 & TA-185)

**C** - The time-saving quick-attach system adds the versatility you need to take on any material handling situation. The simple design is strong, doesn't require any tools and has fewer moving parts to wear out over time.

**D** - Loaders are stone black in color with attractive tractor matching decals; however, for you brand loyal enthusiasts who would like your loader painted to match your tractor, just let us know and allow a few extra days for your custom loader to arrive.

**E** - The loader's tower doubles as a grill guard and support system for the loader when in the dismantled position.



# TA-185

New shape and custom features

2WD 20-90 HP »  
4WD 20-80 HP »  
4725# at 11'

For the heavy-duty user and contractor. This loader has a professional feel, lower profile fit with high lift, bucket linkage, tapered bucket, reinforced arms, and in-line valve with precision joystick. The TA-185 includes a new contoured shape, wider frame to accommodate side mount mufflers, skid steer adapter and 72" skid steer bucket.

- |  |  |
|--|--|
| <b>TA-185 Base package:</b>  | <b>Options:</b>  |
| <ul style="list-style-type: none"> <li>• 2-1/2" Bucket Cylinders</li> <li>• 2-1/2" Lift Cylinders</li> <li>• Hydraulic Power-Mount™</li> <li>• Skid-Steer Quick-Attach</li> <li>• Mounting &amp; Hose Kit</li> <li>• Precision Valve w/Regen Spool</li> <li>• Precision Joystick</li> <li>• Bucket Gauge Rod</li> <li>• 72" Skid Steer Bucket</li> </ul> | <ul style="list-style-type: none"> <li>• Hydra-Snap™</li> <li>• Comfort Ride</li> <li>• Attachments (pp. 26-27)</li> </ul> |



# Just Swap It!

Whether you're moving brush or maintaining the driveway, using the "right tool for the job" is easy. Westendorf's time-tested quick-attach system is simple, reliable and will put a smile on your face every time you use it.

Read more about material handling attachments... »  
pp. 102-117



## Quick Attach



**Modern design is tool free solution; plus, it's simple and reliable**

The simple quick-attach design has fewer moving parts to wear out over time which makes the Westendorf quick-attach system more reliable while reducing the time required for maintenance. This system has been tested over time and proven to work well in the compact tractor industry. It is superior to the universal skid-steer coupler as it is lighter in weight allowing you to lift more payload with your loader.

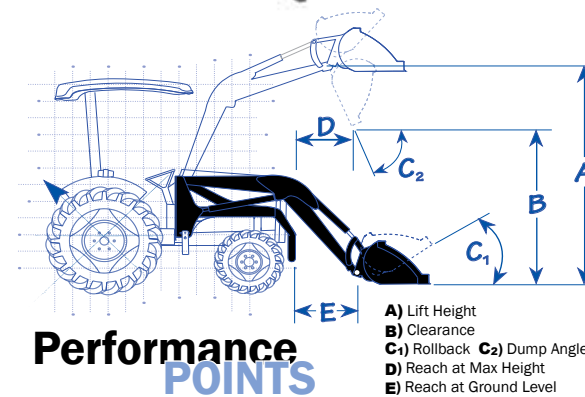

Increase your tractor's value the "cool" way... SEE » PAGE 126



## 100 Series Attachments



	DB-60	SBB-5	SBB-6	VP-72	FLA-42	FLM-42	SP-160	BTA-48	BT-60	BC-3000	BC-4000	BC-7700
<b>TA-52</b>	●	●			●			●		●		
<b>TA-55</b>	●	●			●			●		●		
<b>TA-111</b>	●		●	●		●			●		●	(1)
<b>TA-140</b>	●		●	●		●			●		●	(1)
<b>TA-160</b>	●		●	●		●	●		●		●	(1)
<b>TA-170</b>	●		●	●		●	●		●		●	(1)
<b>TA-175</b>	●			●					●		●	●
<b>TA-180</b>	●		●	●		●	●		●		●	(1)
<b>TA-185</b>	●			●					●		●	●

(1) Requires skid-steer adapter

	TA-52	TA-55	TA-111	TA-140	TA-160	TA-170	TA-175	TA-180	TA-185
Tractor HP Rating (approximate)	10-24 HP	10-24 HP	17-35 HP	15-35 HP	20-60 HP	20-70 HP	20-70 HP	20-90 HP	20-90 HP
<b>A</b> Full Height (ground to pin - feet/inches)	6'1" / 73"	7'2" / 86"	8'3" / 99"	7'7" / 91"	9'5" / 113"	10'2" / 122"	10'2" / 122"	11' / 132"	11' / 132"
<b>B</b> Clearance (bucket dump - inches)	52"	69"	78"	68"	96"	98"	98"	109"	109"
<b>C<sub>1</sub></b> Dump Angle   <b>C<sub>2</sub></b> Rollback Angle	20°   45°	15°   45°	15°   55°	22°   47°	30°   31°	27°   51°	27°   51°	16°   49°	20°   60°
<b>D</b> Reach at Max Height	24"	22"	27"	40"	33'	18"	18"	28"	28"
<b>E</b> Reach at Ground Level (to pin)	12"	12"	17"	22"	20"	24'	24"	22"	22"
Lift Capacity - AWC* (19.65" from pin)	1800 psi   2200 psi 900+   1100+	1800 psi   2200 psi 700   855	1800 psi   2200 psi 1400   1710	1800 psi   2200 psi 1400   1710	1800 psi   2200 psi 1650   2020	1800 psi   2200 psi 1450   1770	1800 psi   2200 psi 2250   2750	1800 psi   2200 psi 2880   3520	1800 psi   2200 psi 2880   3520
Lift Capacity - at Pivot Pin	1200+   1350+	940   1150	1880   2300	1880   2300	2210   2700	1950   2380	3020   3690	3865   4725	3865   4725
Lift Cylinder - Std	1-1/2"	1-1/2"	2"	2"	2"	2"	2-1/2"	2-1/2"	2-1/2"
Bucket Cylinder - Std	1-3/4"	1-3/4"	2"	2"	2"	2"	2"	2-1/2"	2-1/2"
Bucket Sizes Available	48", 54"	48", 54"	60", 66"	60", 66"	60", 66"	60", 66", 72"	60", 66", 72"	60", 66", 72"	60", 66", 72"

\*For additional information on AWC Capacity - see page 11.

Note: Above specifications are based on ASABE S301.3 standard. Specifications may vary depending on make and model of tractor, front axle configuration, tire size, hydraulic system and type of attachment. Design specifications are subject to change without notice or obligation.